

Lab-Volt®

MECHATRONICS & INDUSTRIAL MANUFACTURING TECHNOLOGY

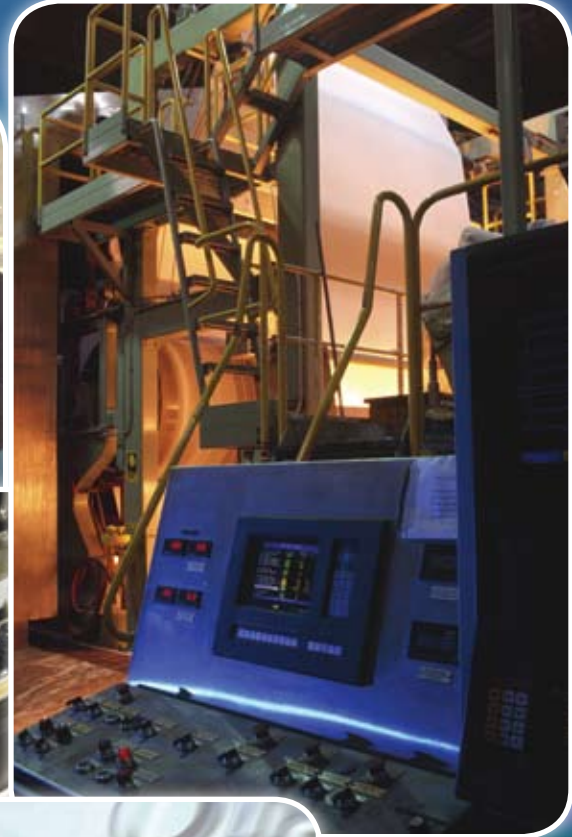
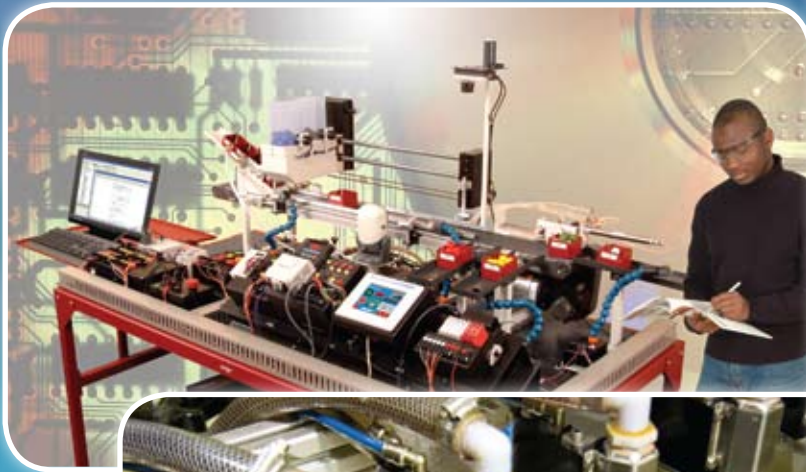

- ELECTRICAL & MECHANICAL SYSTEMS
- HYDRAULIC AND PNEUMATIC SYSTEMS
- PLCs AND DRIVES
- INSTRUMENTATION & PROCESS CONTROL
- HEATING, VENTILATION, & AIR CONDITIONING (HVAC)
- WEB-BASED INDUSTRIAL TRAINING
- AUTOMATION & ROBOTICS
- COMPUTER-BASED LEARNING FOR ELECTRONICS TRAINING (FACET)
- ELECTROMECHANICAL SYSTEMS (EMS)
- EXPLORING TECHNOLOGY

MECHATRONICS & INDUSTRIAL MANUFACTURING TECHNOLOGY

Known as the standard for technical training systems in use across virtually every industry and around the globe, Lab-Volt is now using its expertise to facilitate training in Mechatronics and Industrial Manufacturing Technology.

Mechatronics is a facet of engineering science based on a combination of mechanical engineering, electrical engineering, and computer science, and is fundamental to all forms of systems, device, and product designs that incorporate a balance of mechanical structure with electronic and software control technologies. Common examples of the application of mechatronics can be found in the auto industry and include antilock brake systems (ABS), stability control, memory-adjust seats, and climate control. Mechatronics applications can also be found in most everyday tasks, from making coffee to washing laundry to accessing a computer hard drive, as well as many not-so-everyday tasks, like the operation of an MRI machine or a robotic assembly system. Mechatronics also encompasses pneumatics and hydraulics systems and just about anything else that involves or controls motion.

Mechatronics engineers, by necessity, must be cross-trained in several disciplines and must also have the ability to communicate across these disciplines. They must be able to install machines, connect them to electronic circuits, and master their control software. Such skills put mechatronics specialists in high demand in the workforce. In fact, well-known consumer products leader Procter & Gamble Co. trains all new hires in Mechatronics.

The need for mechatronics engineers goes far beyond the consumer goods industries, and includes (but is certainly not limited to) technology, aerospace, and agriculture. Consider

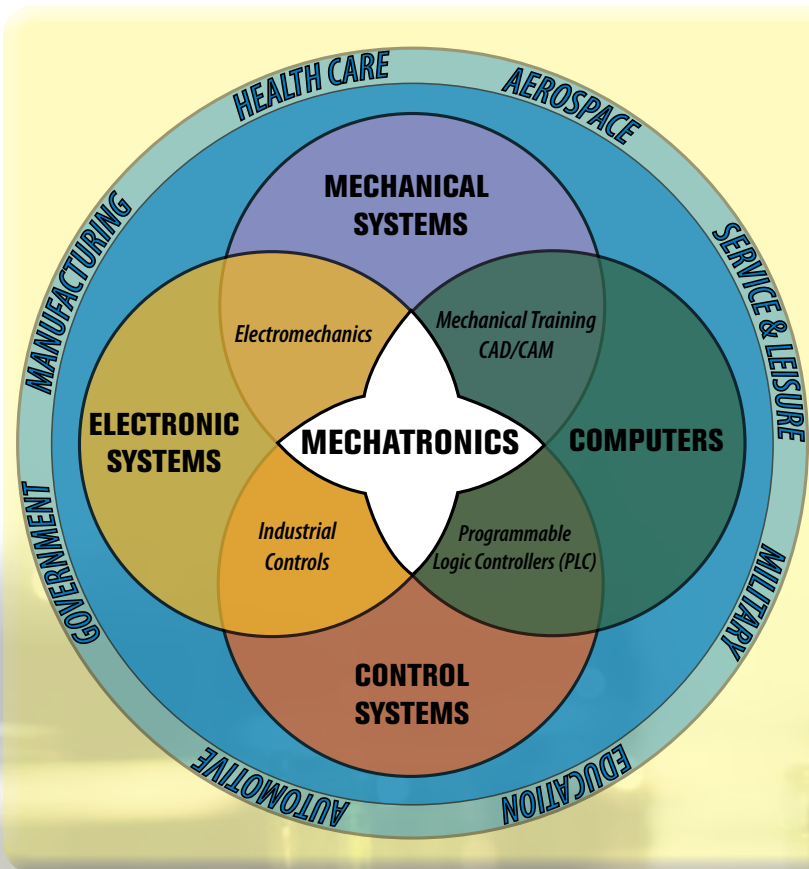

the farming industry. A tractor was once a fairly simple, if vital, piece of farming equipment. Today's still-vital tractors, are often used for precision farming and equipped with global positioning systems (GPS), radar guns, hands-free operation, computers, and touch screens; a complex integration of mechanical, fluid power, electrical, and software components. Lab-Volt recognizes the special nature of Mechatronics and Industrial Manufacturing in the 21st century. Many industries combine factors more unique and specialized and having more complicated relationships than most traditional occupations, and Lab-Volt is prepared to provide training that meets or exceeds industry expectations.

Accustomed to breaking down processes and procedures into elemental blocks, Lab-Volt's Mechatronics and Industrial Manufacturing Technology training systems take the eso-

Lab-Volt's Mechatronics Training Program includes:

- Electricity & Electronics
- Electrical & Mechanical Systems
- Electric Power & Controls
- Fluid Power Systems
- PLCs & Drives
- Automation & Robotics
- Instrumentation & Process Control
- Manufacturing Technologies
- Web-Based Industrial Training

teric and theoretical out of the laboratory and translate it into apparatus that introduce practical, understandable teaching methods in each of the disciplines required to be successful in this field

Since the postwar technology boom of the 1950's, Lab-Volt has been helping to train the minds and hands of the specialists and technicians who make the possible practical. Lab-Volt has maintained its leadership by combining expertise in virtually all scientific, technological and industrial disciplines with the ability to envision the most efficient and effective means to educate within the training center and classroom environments. The result is a wide range of training apparatus that consistently produces awards for the company, and qualifies technical specialists for virtually every field of endeavor.

Lab-Volt training systems are proven and trusted worldwide by educators operating in all sectors, including schools and universities, vocational training, government and the military, commerce and industry, and more. Lab-Volt supports all of its products with state-of-the-art service centers in the United States and Canada, and a comprehensive network of product technicians standing by worldwide.

Lab-Volt also recognizes the need to nurture, through early education, an interest and excitement in mechatronics and manufacturing concepts and technologies in order to secure future innovations in this field. Interactive, hands-on programs for middle and high school students spark the imagination, interest, and desire to pursue this field through higher education and beyond.

New knowledge is flowing constantly in both directions between the laboratory and the installation. Lab-Volt is proud to be the facilitator of that transfer, helping the researchers develop better and more efficient technology, helping the designers determine the most practical means to use that technology, and helping train technicians who will install and maintain the equipment for best performance, longevity, and reliability.

Regardless of the operational scale of the mechatronics and industrial manufacturing sources, Lab-Volt has distilled the essential elements of the process down to safe, hands-on classroom applications, developing each training product and process to yield realistic, repeatable, and logical results. Contact your Lab-Volt representative today to discuss your training challenges. Lab-Volt can suggest, adapt, or customize a training system to work perfectly within your program.

PURSuing A COURSE OF STUDY IN MECHATRONICS

In recent years, the development of Mechatronics programs has seen tremendous growth, nationally and internationally. An ever-increasing number of industries and technologies, such as aerospace, agriculture, computer technologies, consumer goods, forestry, and health care, are hiring mechatronics engineers as integral elements of their workforces. This is due, in large part, to the fact that those trained in mechatronics technologies have the ability to work across disciplines, combining appropriate technologies to create cost-effective, reliable solutions and devices. Mechatronics is a growing field with a growing demand for qualified employees who possess an inherent curiosity in varied technologies.

A career in mechatronics requires an interest in understanding engineering design and being able to define, organize, classify and integrate the parts of a design into a coherent result. A hands-on approach to problem-solving, a creative drive, and interdisciplinary communication skills are also significant when pursuing a career in mechatronics.

Lab-Volt's Mechatronics and Industrial Manufacturing Technology training systems provide a comprehensive solution for those whose future is in this vibrant field.



ADVANCED MECHATRONICS

- Robotics & Automation Systems
- PLC Interfacing Systems Design
- Power Electronics
- Motion Control: Rotary & Linear
- Instrumentation & Process Control

INTERMEDIATE MECHATRONICS

- Basic Process Control
- Servo Controls
- AC/DC Drives
- Hydraulic Servo
- Pneumatic Servo
- PLC Programming
- Electrical/Electronic Control of Fluid Power

MECHATRONICS FOUNDATION

- Electricity
- FACET Electronics
- Mechanical Systems
- Pneumatic Systems
- Hydraulic Systems
- Electric Power Systems
- PLC Fundamentals

Electrical & Mechanical Systems 4

Mechanical Training System, Model 46101 5
 Industrial Wiring Training System, Model 46102 6
 Pumps Training System, Model 46106 7
 Rigging System, Model 46109 8
 Piping System, Model 46105 9
 Industrial Controls Training System, Series 8036 10

Fluid Power 11

Fluid Power Training for Industrial Applications 11
 Simulation Software 12
 Hydraulics Fundamentals, Model 6080-1 13
 Electrical Control of Hydraulic Systems,
 Model 6080-2 14
 Pneumatics Training Systems, Model 6081-1 & -2 15
 Advanced Fluid Controls Applications 17
 Hydraulics and Pneumatics Simulation
 Software (LVSIM®-HYD) 19
 Fundamental Fluid Power Trainer, Model 6059 20

**Computer-Based Learning
 for Electronics Training (FACET) 21**

FACET Series 91000 21

Electromechanical Systems (EMS) 22

0.2-kW Electromechanical Training
 System, Model 8001 22
 Computer-Assisted 0.2-kW Electromechanical
 Training System, Model 8006 23

Automation & Robotics 24

Introducing Lab-Volt Automation 24
 Flexible Manufacturing System, Model 5901 25
 Programmable Logic Controller (PLC),
 Series 3240 26
 Programmable Logic Controller (PLC),
 Series 3270 27
 Programmable Logic Controller (PLC),
 Models 5930 & 3128 28
 PLC Applications, Series 8075 29
 PLC Simulation Software, (P-SIM 2000),
 Model 91773 31
 Robots and Robot Software 32
 RoboCIM Software 33
 CNC Lathes and Mills 34
 CNC Software for Mill and Lathe 35
 Fabricus Software 36
 CAD/CAM Software for Mill and Lathe 37
 Teach Pendant-Controlled Robot System,
 Model 5100 38
 Computer-Controlled Robot System, Model 5150 38

Servo Robot System, Model 5250 39
 Robot Equipment Options 40
 Bench Options 41
 CNC Lathe, Model 5300 42
 CNC Lathe, Model 5500 43
 CNC Mill, Model 5400 44
 CNC Mill, Model 5600 45

Instrumentation and Process Control 46

Bench-Top Trainers, Models 3521 & 3522 46
 Instrumentation & Process Control, Model 3530 47
 Process Control, Model 6090 49
 Mobile Instrumentation & Process
 Control, Model 3500 51
 Process Control Stations, Models 3505, 3507,
 3508, & 3550 52
 Process Control and Simulation Software (LVPROSIM),
 Model 3674 53

Web-Based Industrial Training 54

Industrial Training Zone by Lab-Volt 54
 Industrial Mechanical, Model 47904 54
 PLC Fundamentals, Model 47910 54
 Industrial Hydraulics, Model 47901 55
 Mobile Hydraulics, Model 47906 55
 Industrial Pneumatics, Model 47902 56
 Pneumatic Specialist, Model 47909 56
 Industrial Electrical, Model 47903 57
 Mobile Electrical, Model 47907 57
 AC/DC Motors and Drives, Model 47908 57

**Heating, Ventilation, &
 Air Conditioning (HVAC) 58**

Refrigeration Training Systems
 Models 3400 & 3401 59
 Refrigeration Training Systems
 Models 3402 & 3403 60
 Refrigeration Training Systems
 Models 3404 & 3406 61
 Refrigeration Training System with Data
 Acquisition, Model 3431 62
 Refrigeration Skills Trainers 63

Exploring Manufacturing Technology 64

Lab-Volt Exploring Technology Series 64
 Exploring Sensors, Model 3341 64
 Exploring Mechanisms, Model 3342 65
 Exploring Electricity, Model 3343 65
 Practical Electricity and Electronics
 Trainer (PEET), Model 556 66
 Laboratory Instrumentation System, Model 438 66

ELECTRICAL & MECHANICAL SYSTEMS

The Transition From Classroom to Workplace is Seamless with Lab-Volt's Industry-Relevant Training

Lab-Volt understands the need for highly skilled employees in many sectors of the economy, including manufacturing, health care, service and leisure industries, government, education, and the military. Lab-Volt's mechanical training systems provide trainees with all the knowledge, skills, and practical experiences needed for a rewarding career in industrial maintenance, whether they are college-bound or aim for employment after graduation.

Each model consists of comprehensive courseware, including a training manual and instructor guide. These materials provide everything needed to ensure safe, effective training and verification of trainees' skill development.

FEATURES

- Industrial grade equipment
- Task-based learning through job sheets, work orders, and reference material
- Workplace topics such as health, electrical safety, and tool safety are enforced
- Interdisciplinary learning allows for flexible career options
- Trainees gain solid employability skills, such as communication, troubleshooting, teamwork, work measurement, problem solving, and critical thinking
- Optional workbenches and simulation software save training dollars and space
- Modular design and various lab configurations allow for customization of curriculum

Models include:

MECHANICAL TRAINING SYSTEM

Model 46101

INDUSTRIAL WIRING TRAINING SYSTEM

Model 46102

PUMPS TRAINING SYSTEM

Model 46106

RIGGING SYSTEM

Model 46109

INDUSTRIAL CONTROLS TRAINING SYSTEM

Model 3100



Heavy-duty motor mounting base from the Mechanical Training System

VARIABLE SPEED DRIVES

- DC Variable Speed Drive, Model 3250
- AC Variable Speed Drive, Model 3260

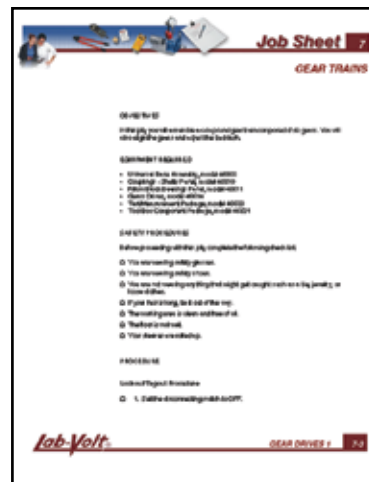

Students follow job sheets and work orders to complete tasks safely and efficiently

MECHANICAL TRAINING SYSTEM

Model 46101



Shown with optional components.

The Lab-Volt Mechanical Training System, Model 46101, familiarizes students with the selection, installation, use, maintenance, and troubleshooting of mechanical drive components.

Engineered for extreme ease of use, the system comes with a universal steel base unit on which the students prepare the setups using T-slotted extrusion bars. This innovative design allows the base to be configured as required by the task. The universal base includes a disconnecting switch, current meter, and the controls required to operate the motors and clutch-brake. It also includes a Start/Stop push-button station for local and remote operation.

The curriculum is based on practical, hands-on tasks using industrial grade components. This ensures that students are well prepared for today's competitive workforce.

TOPIC COVERAGE

- Universal base unit can be mounted on a regular table as well as optional Lab-Volt benches
- Fully illustrated job sheets direct students to complete tasks safely and efficiently
- Lockout/tagout on the disconnecting switch and safety panels ensure student safety
- Working space can be increased by adding a slave base unit
- Quality industrial components are mounted on panels for storage and inventory control

FEATURES

- | | |
|-------------------|-----------------------|
| ● Belt Drives | ● Bearings |
| ● Chain Drives | ● Ball Screws |
| ● Gear Drives | ● Gaskets and Seals |
| ● Lubrication | ● Clutches and Brakes |
| ● Couplings | ● Laser Alignment |
| ● Shaft Alignment | ● Vibration Analysis |

INDUSTRIAL WIRING TRAINING SYSTEM

Model 46102



The Lab-Volt Industrial Wiring Training System, Model 46102 faithfully reproduces an industrial environment where students can develop their skills in the installation and wiring of industrial electrical equipment, in compliance with the National Electrical Code® (NEC®). The system can also be used to teach trainees how to adjust and maintain industrial electrical equipment as well as enforce the safety rules to be followed when working at industrial sites.

Due to its modular design, the Industrial Wiring System can be configured to fit various training needs. A versatile, mobile workstation is the basis of the system. A variety of equipment packages, tool packages, and industrial application packages are available to adjust the curriculum to customized training levels. Packages of consumable goods such as conduits, conduit fittings, dummy electrical enclosures and boxes, and reels of electrical wire are also available.

TOPIC COVERAGE

- Cabinet Installation
- Conduit Installation
- Industrial Equipment Wiring
- Electrical Safety

- Electrical Diagrams
- Power Distribution
- Motor Starters
- AC/DC Drives
- Industrial Applications

FEATURES

- Supports up to four equipment setups at the same time, allowing multiple student groups to work at a single workstation
- Two or more equipment setups can be grouped together to form complex industrial applications
- Selection of equipment packages allow the system to meet a wide range of training objectives
- Fully illustrated courseware guides students through various tasks
- Mobile workstation features swivelling casters with a lock mechanism for easy motion and stable operation
- Sized to fit through standard door openings

PUMPS TRAINING SYSTEM

Model 46106



The Lab-Volt Pumps Training System, Model 46106, familiarizes students with maintenance tasks such as pump installation, lubrication, shaft alignment, inspection, and component replacement. Students also learn how to start up, operate, and troubleshoot industrial pumps in different configurations. Furthermore, during these hands-on activities they will discover the impact of valve restriction, air injection, and Net Positive Suction Head (NPSH) on pump efficiency by using a cavitation valve, a load valve, and two different water reservoirs.

The modularity of the system permits the selection of models required to meet customized training objectives.

TOPIC COVERAGE

- Pump Installation
- Lubrication
- Shaft Alignment
- Inspection
- Component Replacement
- Valve Restriction
- Air Injection
- Pump Wiring
- Fluid Mechanics
- Pump Maintenance
- Laser Alignment
- Vibration Analysis

FEATURES

- Thirteen different types of pumps
- Latest 3-phase AC drive included to vary the speed of motor-driven pumps
- Easy electrical connections between the drive and motor can be made using banana jacks or terminal blocks
- Configure variable speed drives using local panels, or remotely using optional computer software
- Transparent pump cover allows cavitation observation



Industrial quality pumps are used for the most realistic training

RIGGING SYSTEM

Model 46109



Moving machines is a basic requirement for any industrial plant. Machines to be moved are all different since they are usually built for a special application. They have different shapes and are often asymmetrical. Their weight, which is not evenly balanced on the machine supports, creates difficulties to the rigger. Therefore, installation requires skilled and highly qualified riggers.

To help acquire these basic skills, the Lab-Volt Rigging System was created to cover the fundamentals of rigging practices. Students practice the techniques that must be developed and used to install and move a machine safely.

Work orders help students develop the skills required for rigging practice and are an excellent test bench for the students.

TOPIC COVERAGE

- Moving machines using rollers
- Lifting and handling odd-shaped loads
- Moving loads according to center of gravity and weight
- Handling machines with wire rope pullers
- Identify different types of rope, cut rope properly, and make knots
- Assemble a wedge socket on a wire rope
- Install hoist trolleys, chain links, chain hoist, and electric hoist on the gantry crane
- Move a machine from ground position to a pedestal
- Lift an unbalanced load

FEATURES

- Storage for all material
- Work orders for task-based learning
- Industrial-grade equipment

PIPING SYSTEM

Model 46105



The Lab-Volt Piping Training System faithfully reproduces an industrial environment where students can develop their skills in the fabrication, installation, and testing of industrial piping systems, including pipes, tubing, and hoses.

The system can also be used to teach how to perform maintenance on industrial piping systems, as well as enforce the safety rules followed at industrial sites.

Due to its modular design, the Piping Training System can be configured to fit various training needs. A versatile mobile workstation is the basis of the system. All components and tools are industrial grade for realistic training and durability.

TOPIC COVERAGE

- Motor Operators
- Pipes and Pipe Fittings
- Valve Types and Operation
- Safety Valves
- Steam Traps
- Valve Maintenance
- Fabrication, Assembly, and Installation
- Measurement and Layout
- System Testing
- Safety Rules and Procedures

INDUSTRIAL CONTROLS TRAINING SYSTEMS

Series 8036



The Lab-Volt Industrial Controls Training System, Series 8036, has unique controls training capabilities, which are enhanced by its modularity and its instructor-inserted faults. The system allows students to select and mount control devices to form typical control circuits, and to troubleshoot them once a fault is inserted.

The Industrial Controls Training System is divided into four levels, each level being further divided into specific topics that deal with various aspects of industrial controls equipment operation:

- Basic Controls System, Model 8036-1: Provides students with complete basic training in motor controls.
- Programmable Logic Controller System, Model 8036-2: Introduces the use of PLCs to control the motor operation.
- Motor Drives System, Model 8036-3: Introduces the use of the DC and AC drives.
- Sensors system, Model 8036-4: Introduces photoelectric and proximity switches.

The control devices and motors in the 8036 Series are of standard industrial quality, preset to fit the 0.2 kW machines in the Electromechanical Training System. Device designations can be added to each module with magnetic labels.

Each module is equipped with up to four faults that can be inserted by the instructor using switches mounted

behind the faceplate. Typical faults include open coils and contacts, dirty contacts, shorted connection, and crossed wires.

The modules of the 8036 Series are designed to be mounted in the Mobile Workstation, Model 3103-3, or in the Workstations, Models 3104-1 and 3105. These Industrial Controls Training System modules can also be interconnected with those of other Lab-Volt training systems for interdisciplinary training applications. Connections are made using flexible PVC-insulated connecting leads terminated with 4-mm safety plugs. These leads allow safe connection of components, since the live parts of their plugs are concealed and insulated so they cannot be contacted accidentally. Leads come in three different lengths, each identified by a distinctive color. Smaller connection leads are also provided for the low-voltage applications running with 24 Vdc

TOPIC COVERAGE

- Basic Principles of Electric Motor Control
- Circuit Layout and Specifications
- Basic Control Circuits
- Jogging Control Circuits
- Reduced AC Voltage Starters
- Time Relay Circuits
- Programmable Logic Controller
- PLC Control Circuits
- AC Drive
- DC Drive
- Sensors
- Troubleshooting

OPTIONS Training Options



Lab-Volt offers the most comprehensive and flexible course in fluid power available. Lab-Volt's premier training system for fluid power technology consists of two programs. The Hydraulics Training System, Model 6080, and the Pneumatics Training System, Model 6081. Both are innovative, modular systems that use state-of-the-art hardware and courseware to deliver job training in fluid power.

The entire fluid power series has been designed for educational growth. Using either the Hydraulics or the Pneumatics Training Systems, students gain a solid foundation in, and hands-on experience with, fluid power components and circuits; the principles and concepts underlying fluid power systems and applications; and methods of troubleshooting and testing fluid systems. Each lesson builds upon previous lessons, making this an ideal job-training program.

Engineered for extreme ease of use, the core system begins with a work surface assembly consisting of a solid metal, universal drip-tray hinged to a perforated, tiltable work surface that serves as a panel onto which hydraulic or pneumatic components are mounted. By adding optional expansion panels, the work surface can be configured to accommodate a wide variety of space and teaching needs. Mounting and dismounting components is easy with push-lock fasteners that snap easily into the perforation on the work surface. The tilting work surface facilitates instructor demonstration to an entire class.

The scope of the entire Lab-Volt Fluid Power product line addresses the diverse needs of secondary and post-secondary technology programs. The interfacing of electronics, sensors, robots, and controls makes the Lab-Volt program an ideal cornerstone of any job-training program in Mechatronics, Electromechanical Systems, or Automation.

The courseware includes reference textbooks, optional video tapes and courseware illustrations. The illustrations are available in the form of transparencies and on CD-ROM.

The courseware for Hydraulics Fundamentals and Pneumatics Fundamentals is also available in a Computer-Based Learning format. The CBL version enables electronic grading of review questions and unit tests. For those who purchase this version, an Instructor Answer Key is provided. All other hardware and supporting materials remain the same as the book course.

VERSATILE AND FLEXIBLE SYSTEMS FIT ANY CLASSROOM CONFIGURATION

The basic Lab-Volt Hydraulics Training System consists of a power unit, work surface assembly, industrial grade components, hoses, hose rack, metering instruments, and related courseware. The basic Pneumatics Training System consists of a work surface assembly, pneumatic components, measuring instruments, accessories, and related courseware. All components in both systems exceed industrial safety standards, and are identified with ANSI symbols. Optional equipment includes a mobile support bench with expandable storage shelves, dress panels, and additional expansion panels.

Operating on a standard electrical supply, the Hydraulics system requires no special wiring. The power unit was designed to match components with training needs. The pump delivers flow to components at a rate that allows observation and is powerful enough to provide pressures in excess of 6200 kPa (900 psi).

HYDRAULICS PNEUMATICS

Time and Space

To provide training centers and students with a fast and effective instructional tool, Lab-Volt has created a series of Windows®-based simulation software programs (LVSIM®) that cover the same material and produce the same results as actual laboratory equipment. The Lab-Volt Hydraulics and Pneumatics training systems, Models 6080-1/2 and 6081-1/2, are also available as simulation software programs through the LVSIM® trademark.

LVSIM®-HYD (Model 6385) and LVSIM®-PNEU (Model 6485) cover the same courseware as the standard programs, but standard laboratory equipment is replaced by computer-screen images that fully simulate the mechanical characteristics of the actual hydraulic and pneumatic modules. Using the mouse, students can select and set up virtual equipment for a given exercise, make the necessary connections between the simulated modules, and obtain the same results as with the real equipment.

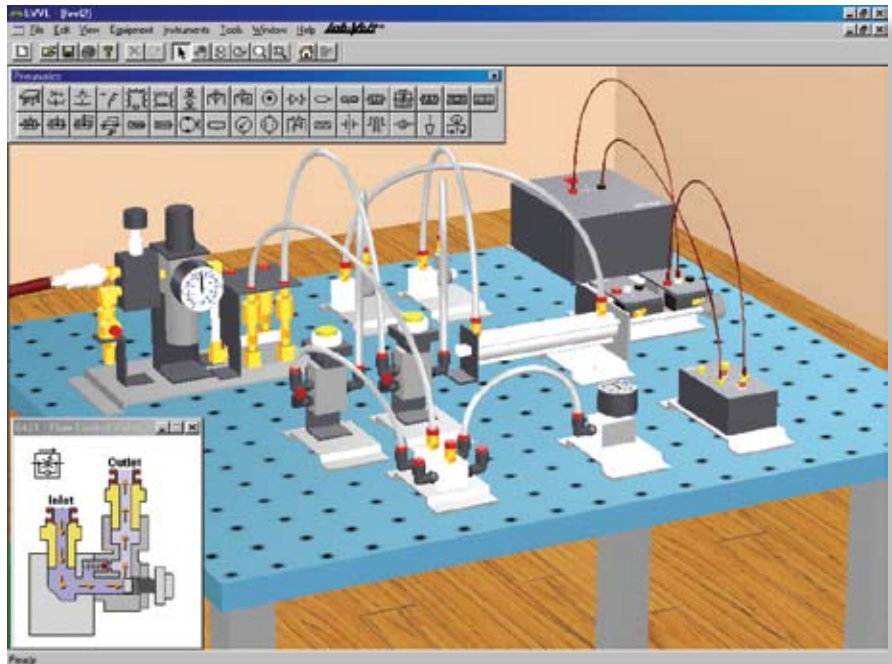

Used either as a complement to the actual laboratory equipment or as a stand-alone product, LVSIM® is a cost-effective tool that enables students to safely and accurately perform experiments and become familiar with the equipment configuration and laboratory setup before they enter the lab. As a result, their time spent in duplicating hands-on tasks in the actual laboratory may be reduced significantly, resulting in the need for less physical hardware per student. With these cost-saving features, institutions with tight budgets can deliver a quality program in hydraulics and pneumatics with limited investment.

An additional advantage to LVSIM® is its protected portability. Students can install the software onto their own personal computers in order to practice and prepare in advance for their lab exercises, but measurement capability is restricted by means of a security hardlock device.



HYDRAULICS FUNDAMENTALS TRAINING SYSTEM

The Hydraulics Fundamentals Training System, Model 6080-1, gives students a solid foundation in, and hands-on experience with, hydraulic components and circuits; the transmission of force through liquids; conversion of force to pressure; the control of power; and methods of troubleshooting hydraulic systems.

The standard modular system consists of a perforated work surface, components for the Hydraulics Fundamentals course, a drip tray attached at the bottom of the work surface, a hose rack with hydraulic hoses, and a mobile power unit with a dead-weight stand.

The work surface of the 6080-1 can be placed on a table or an optional bench, containing sliding channels for storing additional work surfaces, or on a lockable, paneled bench.



Components for Hydraulics Fundamentals

TOPIC COVERAGE

- Introduction to Hydraulics
 - Familiarization with the Lab-Volt Hydraulics Trainer
 - Demonstration of Hydraulic Power
- Fundamentals
 - Pressure Limitation
 - Pressure and Force
 - Flow Rate and Velocity
 - Work and Power
- Basic Circuits
 - Cylinder Control
 - Cylinders in Series
 - Cylinders in Parallel
 - Regenerative Circuits
- Functional Circuits
 - Accumulators
 - Hydraulic Motor Circuits
 - Pressure Reducing Valves
 - Remotely-Controlled Pressure Relief Valves
- Troubleshooting
 - Hydraulics Pump
 - Directional Valve Testing
 - Flowmeter Accuracy
 - Effects of Temperature on System Operation



Work surface on optional bench without dressing panels

FEATURES

- Engineered for extreme ease of use
- Workstation can be configured to accommodate a wide variety of space and teaching needs.
- Components mount/dismount with push-lock fasteners
- Optional support benches and dressing panels are available
- Components exceed industrial safety standards

SYSTEM VOLTAGES

120, 220, 240 V - 50/60 Hz

ESTIMATED PROGRAM HOURS

40 hours

LANGUAGE VARIATIONS

English, French, Spanish

OF HYDRAULIC SYSTEMS

Electrical Control of Hydraulic Systems, an add-on to the Hydraulics Fundamentals Training System, introduces students to electrical concepts and electrically controlled hydraulic systems. Through hands-on experimentation, students gain familiarity with functional and industrial electrically controlled hydraulic systems while learning systematic methods of troubleshooting and testing electrically controlled hydraulic systems.

The same perforated work surface, drip tray, hose rack and hose, and power supply unit are used with the Electrical Control of Hydraulic systems.

TOPIC COVERAGE

- Introduction to Electrical Controls of Hydraulic Systems
 - Familiarization with the Equipment
- Electrical Control Principals
 - Basic Electricity
 - Ladder Diagrams
 - Basic Electrically-Controlled System
- Fundamental Systems
 - Hydraulic Sequencing of Cylinders
 - Electrical Sequencing of Cylinders
 - Speed Regulation and Braking of Hydraulic Motors
 - Continuous Reciprocation with Dwell Period
- Industrial Applications
 - Drilling System
 - Safety Circuits
 - Counting of Actuator Cycles
 - Multi-Pressure Systems
 - Rapid-Traversal Slow-Feed Systems
- Troubleshooting
 - Troubleshooting Electrical Control Circuits
 - Troubleshooting Electrically Controlled Hydraulic Systems

FEATURES

- Seamless integration with Hydraulics Fundamentals System
- Prepares students for jobs and advanced education in state-of-the-art fluid power applications
- Provides add-on capabilities for PLC operations, Servo/Proportional Control, and Sensors
- Integrates with Electrical Control of Pneumatic Systems

SYSTEM VOLTAGES

120, 220, 240 V - 50/60 Hz

ESTIMATED PROGRAM HOURS

60 hours

LANGUAGE VARIATIONS

English, French, Spanish



Components for Electrical Control of Hydraulic Systems



Work surface with "A" frame on optional bench with dressing panels and lockable doors.

PNEUMATIC SYSTEMS

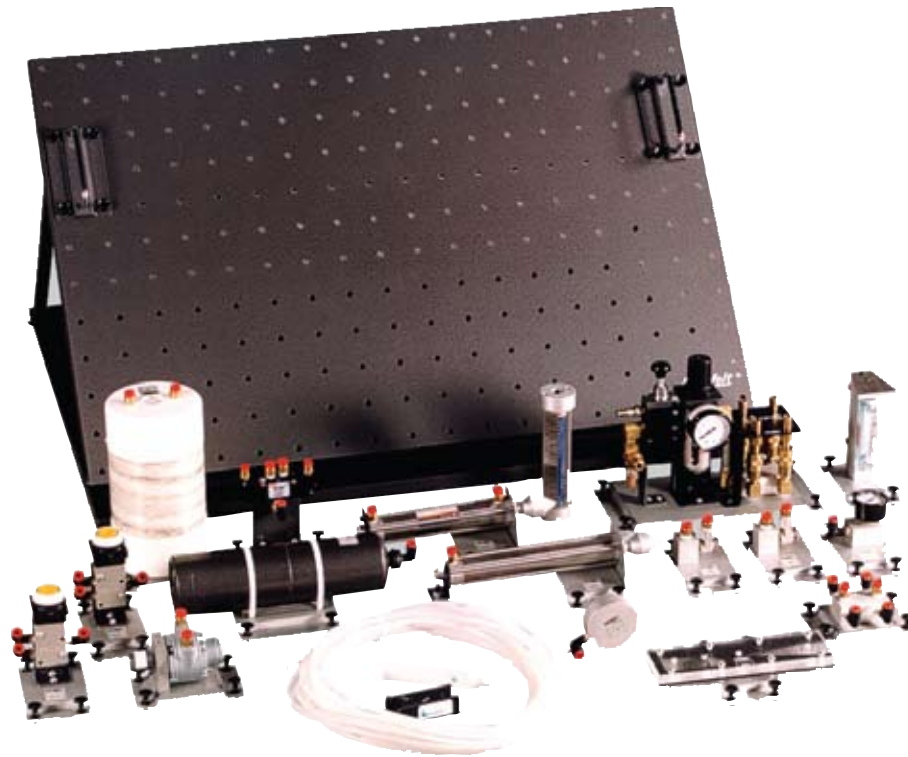

Model 6081-1
Components of Pneumatics Fundamentals

The Lab-Volt Pneumatics Training System is an innovative, modular system that uses state-of-the-art hardware and courseware to deliver comprehensive training in the principles of pneumatic energy and its control applications. The Pneumatics Training System uses the same workbench and many electrical components of the Electrical Control of Hydraulic Systems, Model 6080-2, providing a convenient interconnection between both systems.

The system comes with a work surface assembly consisting of a solid metal, universal drip-tray, hinged to a perforated tiltable work surface. This work surface provides a large area for mounting the pneumatic components, using easy push-lock fasteners. All components meet industrial safety standards and are identified with ANSI symbols.

The Pneumatics Fundamentals Training System, Model 6081-1, gives students a solid foundation in, and hands-on experience with, pneumatic components and circuits; the transmission of force through liquids; conversion of force to pressure; the control of power; and methods of troubleshooting pneumatic systems.

In the second level, Electrical Control of Pneumatic Systems, Model 6081-2, students are introduced to electrical concepts and electrically controlled pneumatic systems. Through hands-on experimentation, students gain familiarity with functional and industrial electrically controlled pneumatic systems while learning systematic methods of troubleshooting and testing electrically controlled pneumatic systems.

The student laboratory manuals provided with the trainer are objective-based and self-paced with procedures that direct the student with step-by-step instructions. A general reference text is also provided for theory and background studies.

Additional options, including a mobile bench with lockable and expandable storage shelves, dress panel, and work surfaces are also available.

TOPIC COVERAGE

Pneumatics Fundamentals

- Introduction to Pneumatics
 - Familiarization with the Lab-Volt Pneumatics Trainer
 - Introduction to Pneumatics
 - Air Conditioning and Distributing Equipment
- Basic Physical Concepts
 - Pressure vs Force Relationship
 - Pressure vs Volume Relationship
 - Pressure Drop vs Flow Relationship
 - Vacuum Generation
- Basic Controls of Cylinders
 - Directional Control Valves
 - Directional and Speed Control of Cylinders
 - Cylinders in Series
 - Cylinders in Parallel
- Basic Controls of Pneumatics Motors
 - Indirect Control Using Pilot-Operated Valves
 - Pneumatic Motor Circuits

**Pneumatics Training Systems,
Models 6081-1 & 6081-2**

(Continued)



Model 6081-2
Components of Electrical Control of Pneumatic Systems

- Pneumatic Motor Performance

Electrical Control of Pneumatic Systems

- Introduction to Electrical Control of Pneumatic Systems
 - Familiarization with the Equipment
- Electrical Concepts
 - Basic Electricity
 - Ladder Diagrams
 - Basic Electricity Controlled Pneumatic Circuits
 - Basic AND and OR Logic Function Circuits
- Functional Systems
 - Basic Memory and Priority Electro-pneumatic Circuits
 - Multi-Pressure Systems
 - Sequencing Pneumatic Circuits
 - Time-Delay Electro-pneumatic Applications
- Industrial Applications
 - Pneumatic Actuator Deceleration Circuits
 - Counting of Actuator Cycles
 - Industrial Drilling System and Safety Circuits
 - Garbage Compactor Simulation Circuit
- Troubleshooting
 - Troubleshooting Electrical Control Circuits
 - Troubleshooting Electrically Controlled

Pneumatics Systems

FEATURES

- Engineered for extreme ease of use
- Workstation can be configured to accommodate a wide variety of space and teaching needs
- Components mount/dismount with push-lock fasteners
- Optional support bench and dressing panels are available
- Components exceed industrial safety standards

SYSTEM VOLTAGES

120, 220, 240 V - 50/60 Hz

ESTIMATED PROGRAM HOURS

Pneumatics Fundamentals: 40 hours
Electrical Control of Pneumatic Systems: 60 hours

LANGUAGE VARIATIONS

English, French, Spanish

PLC APPLICATIONS

**HYDRAULICS & PNEUMATICS APPLICATIONS - PLC
Model 6082**

Using a PLC with either the Hydraulics or Pneumatics Training System, students learn how to send instructions to the PLC and download ladder programs in order to operate fluid power circuits by means of switches, sensors, and solenoid-operated directional valves. The PLC also allows students to make comparison with relay-operated control circuits and design time-delay circuits, up and down counting circuits, latch and unlatch circuits, and more.

Three PLC models are available: Allen Bradley, Omron, and Siemens. Each of them may be programmed using an advanced programming software.

TOPIC COVERAGE

- Programmable Logic Controller Review
- Timer Instructions
- Counter Instructions
- Latching and Comparison Instructions
- Time-Delay Control of Hydraulic Actuators
- Counting Actuator Cycles
- Safety Control of Actuators
- PLC-Controlled Clamp and Work System
- Troubleshooting
- Designing a PLC-Controlled Punching Press (Hydraulics)
- Designing a PLC-Controlled Conveyor System (Hydraulics)
- Designing a PLC-Controlled Die Casting Machine (Hydraulics)
- Designing a PLC-Controlled Stamping Machine (Pneumatics)
- Designing a PLC-Controlled Conveyor System (Pneumatics)
- Designing a PLC-Controlled Injection Molding Machine (Pneumatics)

SERVO/PROPORTIONAL CONTROL
Model 6080-4 Servo/Proportional Control of Hydraulic System and Model 6081-4 Pneumatic Servo/Proportional Control of Pneumatic Systems

The Servo/Proportional Control module is an add-on to the Electrical Control system for both Hydraulics and Pneumatics. Through hands-on operation of signal conditioners, pressure and position transducers, PID controller, proportional directional control valve, feedback devices, and corresponding interface hardware and courseware, students are trained in the precise controls used in industrial applications such as robotics, aviation, CNC machines, marine, mobile equipment, and material handling.

All exercises require Basic and Electrical Control of Hydraulic and/or Pneumatic Systems.

TOPIC COVERAGE
**Servo/Proportional Control of Hydraulic Systems,
Model 6080-4**

- Proportional Directional Control Valves
- Acceleration and Deceleration Control
- Open-Loop Control of Motor Speed
- Proportional (P) Control of Motor Speed

Model 6082
SYSTEM VOLTAGES

120, 220, 240 V - 50/60 Hz

ESTIMATED PROGRAM HOURS

45 hours for each program

LANGUAGE VARIATIONS

English, French, Spanish

Model 6080-4

- Proportional-Plus-Integral (PI) Control of Motor Speed
- Proportional-Plus-Integral-Plus-Derivative (PID) Control of Motor Speed
- Open-Loop Control of Cylinder Rod Position
- Closed-Loop Control of Cylinder Rod Position
- Closed-Loop Control of Cylinder Pressure

FLUID POWER

Servo/Proportional Control of Pneumatic Systems, Model 6081-4

- Introduction to Servo Control Valves
- Acceleration and Deceleration Control
- Open-Loop Position Control
- Closed-Loop Position Control, Proportional (P) Mode
- Closed-Loop Position Control, Proportional-Plus-Integral (PI) Mode
- Open-Loop Speed Control
- Closed-Loop Speed Control, Proportional-Plus-Integral-Plus-Derivative (PID) Mode
- Closed-Loop Pressure Control, Proportional-Plus-Integral (PI) Mode

SYSTEM VOLTAGES

120, 220, 240 V - 50/60 Hz

ESTIMATED PROGRAM HOURS

45 hours for each program

LANGUAGE VARIATIONS

English, French, Spanish

ELECTRONIC SENSORS SET

Model 6085

The Lab-Volt Sensors Training System, Model 6085-A, is designed to familiarize students with the operation of various sensor types. This training system is an add-on to Electrical Control of Hydraulic Systems, Model 6080-2 and Electrical Control of Pneumatic Systems, model 6081-2. It is also available as a stand-alone system. The Sensors Training System contains a selection of photoelectric, inductive and capacitive sensors representative of what can be found in the industry.

Each sensor is mounted on a flexible support attached to a metallic base which can be snapped into the perforations of the Hydraulics and Pneumatics Trainer work surfaces. The sensors are protected against reverse polarity and can be used in conjunction with Programmable Logic Controller to achieve advance fluid control applications.

As a stand-alone system, the Sensors Training System also includes a power supply, pilot lamps, leads, and a work surface.

TOPIC COVERAGE

- Introduction to Sensors
- Diffuse Reflective Photoelectric Switches
- Background Suppression Photoelectric Switches
- Fiber-Optic Photoelectric Switches
- Polarized Retroreflective Switches
- Capacitive Proximity Switches
- Inductive Proximity Switches



Model 6081-4

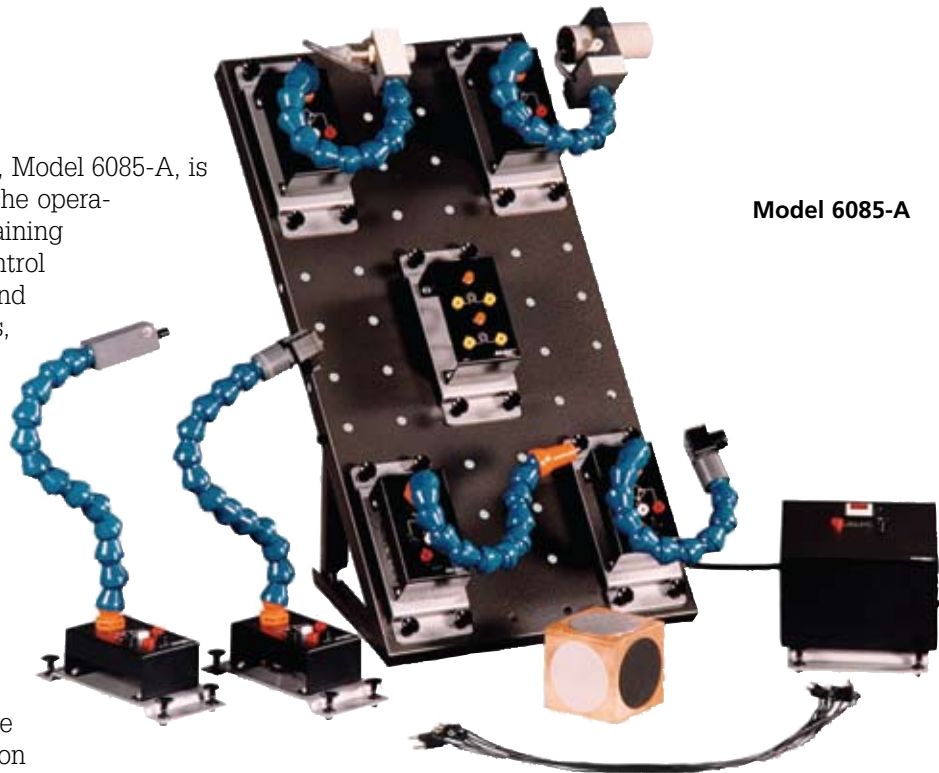

Model 6085-A

SYSTEM VOLTAGES

120, 220, 240 V - 50/60 Hz

ESTIMATED PROGRAM HOURS

18 hours

LANGUAGE VARIATIONS

English, French, Spanish

HYDRAULICS SIMULATION SOFTWARE

The Hydraulics (LVSIM®-HYD) and Pneumatics (LVSIM®-PNEU) Simulation Software are Windows®-based programs that cover the same courseware as Hydraulics and Pneumatics Fundamentals (Models 6080-1 and 6081-1) and Electrical Control of Hydraulic and Pneumatic Systems (Models 6080-2 and 6081-2).

LVSIM®-HYD and LVSIM®-PNEU® recreate a three-dimensional classroom laboratory on a computer screen. The actual equipment of the Lab-Volt Hydraulics & Pneumatics Training Systems is replaced with three-dimensional images, which students can manipulate on the computer screen. Using the mouse, students can install virtual hydraulic and pneumatic equipment in the laboratory, interconnect the equipment, perform a lab exercise, and obtain the same results as with the actual Lab-Volt training equipment.

Sophisticated mathematical models accurately simulate the mechanical and electrical characteristics of the hydraulic and pneumatic components (valves, cylinders, motors, flowmeter, and others) and electrical control devices (switches, relays, pilot lamps, etc.) in the actual Lab-Volt Hydraulics and Pneumatics Training Systems. All components and devices contained in the LVSIM®-HYD and LVSIM®-PNEU® software feature the same functionality and appearance as the actual equipment. Detailed cutaway views of the components can be displayed to observe fluid flow inside components.

Used either as a complement to the actual Hydraulics or Pneumatics Training System or as a stand-alone product, LVSIM®-HYD and LVSIM®-PNEU are cost-effective tools that enable students to perform the experiments provided in the courseware mentioned above. Students may copy the LVSIM®-HYD or LVSIM®-PNEU software onto their own personal computers in order to practice and prepare in advance for their lab exercises. However, measurement capability is restricted by means of a security device.

FEATURES

LVSIM®-HYD and LVSIM®-PNEU enable students to perform the following tasks:

- Install, move, and remove hydraulic and pneumatic components and electrical control devices
- Modify or remove connections at any time
- Zoom in or out to adjust the view
- Perform measurements of flow, pressure, force, velocity and rotation speed
- Observe motor rotation, as well as the extension and retraction of cylinder rods
- Observe fluid flow inside hydraulic and pneumatic components
- Save and restore equipment setups (including the virtual classroom laboratory environment)

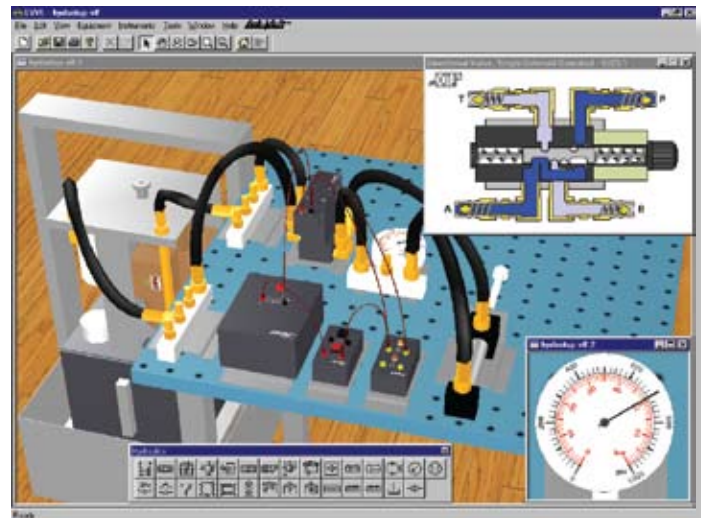

Model 6385 – Hydraulics Simulation Software LVSIM®-HYD.

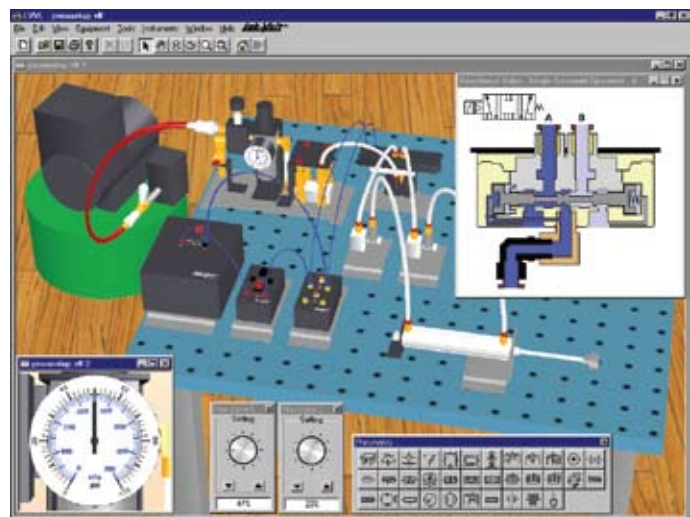

Model 6485 – Pneumatics Simulation Software LVSIM®-PNEU.

VIRTUAL EQUIPMENT

All components from the subsystems for Fundamentals (Hydraulics-6080-1; Pneumatics-6081-1) and Electrical Control (Hydraulic Systems-6080-2; Pneumatic Systems-6081-2) are simulated in LVSIM®-HYD and LVSIM®-PNEU.

PERSONAL COMPUTER REQUIREMENTS

A Pentium personal computer, running under one of the following Microsoft® operating systems, is required to run this software: Windows® NT, Windows® 98, Windows® ME, Windows® 2000, Windows® XP, or Windows® Vista.

LANGUAGE VARIATIONS

English, French, Spanish

FUNDAMENTAL FLUID POWER TRAINER

The Fundamental Fluid Power Trainer, Model 6059, is an introductory program in fluid power concepts, devices, and circuits. The comprehensive Fundamental Fluid Power Trainer includes two instructional trainer modules, and a correlated, two-volume set of student manuals plus instructor guides.

The Fundamental Fluid Power Trainer can be purchased as a complete training program (volumes 1 and 2), or in stages by purchasing Volume 1 and the Volume 2 at a later time. Volume 1 introduces fluid power principles. Volume 2 expands on these principles and covers new fluid power components.

Fluid power components are permanently mounted on removable trays that are stored in a lockable cabinet. Valves and cylinders are made of clear plastic to allow students to view internal parts and better comprehend component functions.

The two-volume set of manuals is presented in eight and six instructional units, respectively. Each unit covers a broad area of fluid power, and contains an objective, a discussion of fundamentals, and several practical exercises that present the material in small instructional segments. Following step-by-step procedures, each student builds simple fluid power circuits using pneumatic components that demonstrate the principles explained in the discussion.



TOPIC COVERAGE

Volume 1, Fundamentals of Fluid Power

- Getting to Know the Trainer
- Fluid Power Fundamentals
- Introduction to Fluid Power
- Compressors and Pumps
- Pressure-Control Valves
- Directional Controls
- Actuators
- Flow Measurement and Control

Volume 2, Fundamentals of Fluid Power

- Getting to Know the Trainer
- Pilot-Operated Valves
- Cam Operated Valves
- Solenoid Operated Valves
- Special Components
- Advanced Applications

FEATURES

- Self-contained cabinet with electric power supply and air compressor
- Easy-to-use controls
- SI and imperial units of measurements
- “Fix-it Shops” that illustrate everyday applications of concepts covered
- Manual, electric, and pilot control
- Clear plastic components to allow viewing of internal parts
- Transparent cabinet top to allow visual inspection and observation of pneumatic power source components

SYSTEM VOLTAGES

120, 220, 240 V - 50/60 Hz

ESTIMATED PROGRAM HOURS

46 hours

LANGUAGE VARIATIONS

English

COMPUTER-BASED LEARNING FOR ELECTRONICS TRAINING (FACET®)

Series 91000

Lab-Volt's FACET® Electronics Training System, Series 91000, is a fully computer-based, modular training system that encompasses four areas of study: Basic Principles of Electricity and Electronics; Digital and Microprocessor Electronics; Industrial Electronics; and Communications. Using the latest instructional technology, FACET is available as an advanced computer-assisted program for the Windows®-based Tech-Lab FACET.

The computer-assisted configuration features powerful delivery, management, and authoring systems used to present, report, and customize the technical subject matter for each of FACET's 30 training modules. This configuration may be used as stand-alone units or as a networked laboratory.

FACET incorporates built-in circuit modification and fault-insertion training capabilities. Students perform experiments on a wide range of analog and digital electricity and electronics training modules that combine theory and application with practical skills training techniques. Each module connects with a required base unit that distributes power and controls the circuits on the board. A complete training station consists of training hardware (any one of the modules plus a base unit and accessory kit), instruments, and student manual or computer-based courseware. The instructor guide and supportive pre- and post-tests provide instructors and students with an extensive overview and working knowledge of analog and digital electricity and electronics.

FACET is suitable for a multitude of training purposes in educational, industrial, and military training laboratories. When a training module is inserted into a base unit, the system functions as an electronics training workstation. Faults and circuit modifications (CM) are set into the circuits, and students then locate, isolate, and troubleshoot the malfunction through a series of troubleshooting steps, including the use of test instruments. Twenty CMs, introduced from the base unit, reduce the need for connecting leads and allow practical assessment of a student's understanding of a circuit.

Lab-Volt's FACET program is continuously expanding. The following modules are currently available:

- 91001 – DC Fundamentals
- 91002 – DC Network Theorems
- 91003 – AC 1 Fundamentals
- 91004 – AC 2 Fundamentals
- 91005 – Semiconductor Devices
- 91006 – Transistor Amplifier Circuits
- 91007 – Transistor Power Amplifiers
- 91008 – Transistor Feedback Circuits
- 91009 – Power Supply Regulation Circuits
- 91010 – FET Fundamentals
- 91011 – Thyristors and Power Control Circuits
- 91012 – Operational Amplifier Fundamentals
- 91013 – Operational Amplifier Applications
- 91014 – Digital Logic Fundamentals
- 91015 – Digital Circuit Fundamentals 1
- 91016 – Digital Circuit Fundamentals 2
- 91017 – 32-Bit Microprocessor
- 91018 – Analog Communications
- 91019 – Transducer Fundamentals
- 91020 – Magnetism and Electromagnetism
- 91022 – Digital Communications 1
- 91023 – Digital Communications 2
- 91024 – Motors, Generators, and Controls
- 91025 – Fiber Optic Communications
- 91026 – Power Transistors and GTO Thyristor
- 91027 – Digital Signal Processor
- 91028 – Transmission Lines
- 91029 – QPSK/OQPSK/DPSK
- 91030 – Microcontroller System Development
- 91091 – Breadboard Module



0.2-kW ELECTROMECHANICAL TRAINING SYSTEM

Model 8001

The Lab-Volt 0.2-kW Electromechanical Training System (EMS), Model 8001, is a modern modular instructional program that represents a new approach to teaching electric power technology by providing new opportunities for laboratory observations. The program, presented in four subsystems and special applications, deals with the different techniques associated with the generation and use of electrical energy. The subsystems cover the common machines, and each subsystem is offered with its courseware presented in a student manual. The special applications deal with less common machines, and the courseware is available in individual leaflet form for each application. Each subsystem is available as a package that consists of the equipment necessary to perform the laboratory exercises presented in the correlated student manual. All machines have cutaway bell housings (front and rear) to permit visual inspection of the internal construction and observation of the machine during operation.

This system was developed by educators to satisfy educational requirements that include industrial applications of electric power technology. The design objective was to develop a low-power educational system with equipment that operates like industrial equipment. Through careful attention to engineering detail, the Lab-Volt EMS System meets this objective, and in so doing, provides laboratory results that are easy to understand, with data values that are easily observed.

The system's modular approach allows new equipment to be added to existing EMS laboratories without needless duplication of equipment. There are two standard module sizes: full size, 308 mm (12.1 in) high, and half size, 154 mm (6.1 in) high. The modules are constructed of heavy-gauge steel, finished in baked enamel. Symbols and diagrams specific to each module are clearly silk-screened on the front panels. Standard, color-coded, 4-mm safety jacks are used to interconnect all system components. All machines have cutaway bell housings (front and rear) to permit visual inspection of the internal construction and observation of the machine during operation. The metering modules are designed to cover the complete range of required measurements with a minimum number of meters. The AC ammeter and voltmeter modules contain three meters for simultaneously measuring all three currents and voltages in three-phase systems. All meters are designed to sustain starting currents even when used on a low range. Wattmeters are internally connected to read power directly when the input is connected to the source and the output to the load. Protection of vulnerable meter components is accomplished without fuses.



Shown with Optional Components

TOPIC COVERAGE

- Investigations in Electric Power Technology
- Power Circuits (Vol. 1)
- DC Machines (Vol. 2)
- Single-Phase Transformers and AC Machines (Vol. 3)
- Three-Phase Transformers and AC Machines (Vol. 4)

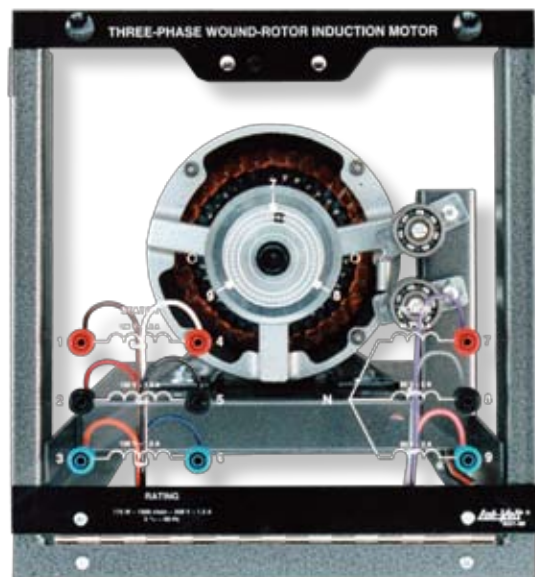

Three-Phase Wound-Rotor Induction Motor

COMPUTER-ASSISTED 0.2-kW ELECTROMECHANICAL TRAINING SYSTEM

Model 8006



Shown with Optional Components

The Computer-Assisted 0.2-kW Electromechanical Training System, Model 8006, is a modern modular program that provides new opportunities for laboratory observations in the study of electric power technology.

The system is based on the same modular approach as the 8001 Training System. However, instead of using pointer measuring instruments, it uses a computer-based system for measuring, observing, and analyzing electrical and mechanical parameters in electric power systems and power electronics circuits. The system's modular approach also allows instructors to start their EMS laboratory with basic courseware and equipment and to add new modules over time without duplication of equipment.

The computer-based system, referred to as the Lab-Volt Data Acquisition and Management for Electromechanical Systems (LVDAM-EMS), Model 9062, allows training in various areas, such as electric power technology, AC/DC machines, and power electronics, using modern and versatile measuring instruments.

Developed by educators to satisfy educational requirements for industrial applications of electric power technology, this program has been designed to meet a variety of training objectives, as follows:

The system has been designed for low-power (0.2-kW or 1/4-hp) educational equipment that enables students to understand and safely operate industrial-type equipment.

Careful attention to engineering detail ensures laboratory results that are easy to understand, data values that are easily observed, and data which, when applied to governing formulas, provides results that verify electrical laws rather than deny them on the basis of large operational-tolerance errors.

As a modular program, course materials provide instructors with complete versatility in selecting and adapting lessons and experiments to fit specific student needs and teaching objectives.

TOPIC COVERAGE

- Fundamentals for Electrical Power Technology
- Alternating Current
- Capacitors in AC Circuits
- Inductors in AC Circuits
- Power, Phasors, and Impedance in AC Circuits
- Three-Phase Circuits
- Single-Phase Transformer
- Special Transformer Connections
- Three-Phase Transformers
- Fundamentals for Rotating Machines
- DC Motors and Generators
- Special Characteristics of DC Motors
- AC Induction Motors
- Synchronous Motors
- Three-Phase Synchronous Generators (Alternators)



The Ultimate Manufacturing/ Mechatronics Training System

For Jobs in CAD/CAM, Robotics, and CNC

As a long-standing leader in industrial technical training systems, Lab-Volt is proud to offer this line of products for hands-on training in automation and robotics. This line of equipment, software, courseware, and accessories is designed to provide students with industry-standard training in integrated manufacturing technology and processes that will prepare them for entry-level jobs in an automated manufacturing environment.

All Lab-Volt Automation products are designed for use in a variety of classroom configurations. They are safe, table top applications, and include high-precision equipment, integrated software, and comprehensive courseware that encompass a wide range of manufacturing applications. The complete line of Lab-Volt Automation products includes:

PLC TRAINING SYSTEM

Model 3240

MANUFACTURING CONVEYOR SYSTEM

Model 3509

FLEXIBLE MANUFACTURING SYSTEM

Series 5901

PROGRAMMABLE ROBOTS

- Model 5100
- Model 5150
- Model 5250

CNC LATHES

- CNC Lathe, Model 5300
- CNC Lathe, Model 5500

CNC MILLS

- CNC Mill, Model 5400
- CNC Mill, Model 5600

SOFTWARE

- File Transfer software for the Teach Pendant-Controlled Robot System, Model 5100
- ROBOCIM software for the Computer-Controlled Robot System, Model 5150
- RoboCIM software for the Servo Robot System, Model 5250
- Lab-Volt CNC software for Mill and Lathe systems
- Fabricus software for the Mill system
- CAD/CAM Software for Mill and Lathe systems

COURSEWARE

- User Guides and Manuals
- Quick Start Manuals
- Student Manuals
- Instructor Guides
- Computer-Based Learning (CBL)



FLEXIBLE MANUFACTURING SYSTEM



The Lab-Volt Flexible Manufacturing System (FMS) consists of two subsystems (Models 5901-1 and 5901-2).

The Flexible Manufacturing System, Model 5901-1, allows students to familiarize themselves with manufacturing applications commonly encountered in modern facilities.

The modular construction of the FMS permits a wide variety of setups allowing students to reproduce the operation of an industrial production line.

Students will be introduced to programmable logic controller (PLC) programming, sensors, DeviceNet network configuration, quality control issues, and troubleshooting of FMS through a series of carefully designed exercises.

The Flexible Manufacturing System (Advanced Applications), Model 5901-2, is an add-on to the Model 5901-1 and provides the latest manufacturing technology equipment to create more sophisticated applications.

FEATURES

- Simulates the operation of a production line in a classroom laboratory
- Modular construction
- Uses the latest manufacturing technology equipment
- PLC controlled operations
- Banana jacks and terminal blocks available on each module
- High-performance Flat Belt Conveyor
- Pneumatic-activated box feeder

- Part Feeder controlled via the DeviceNet network
- Part color detection
- Fault-insertion capabilities in all instructional modules
- Pneumatic activated sorting device
- Emergency Switch Station
- DeviceNet AC Drive
- Allen-Bradley® CompactLogix™ PLC
- PLC compatible with DF1 Full-Duplex Serial (RS-232-C), EtherNet/IP, and DeviceNet networking
- Relay ladder, structured text, sequential function chart, and function block diagram programming
- Sensors mounted on a semi-flexible support
- All modules come with push-lock fasteners for easy mounting on the perforated Work Surface
- Current industry software for PLC programming and DeviceNet networking
- All required electrical leads and pneumatic tubing as well as miscellaneous accessories such as marbles, trays, and boxes
- Pneumatic components equipped with 1/4-in (6.3-mm) quick-connect fittings

TOPIC COVERAGE

- Introduction to Manufacturing
- Human-Machine Interface
- Machine Vision
- Servo Control
- FMS Production Line

The Programmable Logic Controller (PLC), Series 3240, enables students to develop competence in operating, programming, and troubleshooting modern PLC-controlled circuits. The PLC trainer, Model 3240-20, is based on the latest Allen-Bradley Micrologix™ 1200 controller, and is supported by Lab-Volt instructional material. Programming is achieved using the Windows®-based RSLogix™ 500 software from Rockwell Automation. The 3240-20 PLC trainer can be used to achieve PLC control of typical industrial applications implemented with a Mechanical Process Simulator, and of virtual industrial processes simulated by the PLC Simulation Software (P-SIM 2000). The PLC trainer can also be used with the Lab-Volt Industrial Controls Training System, Model 8036, as well as the Lab-Volt Electromechanical Systems, Models 8001 and 8006. The training program consists of two courses covering basic programming to advanced applications. The PLC trainer includes 12 fault-insertion switches for troubleshooting training.

The PLC trainer, Model 3240-A0, is based on the latest Allen-Bradley Micrologix™ 1100 controller, includes an onboard traffic light simulator, and has a built-in 10/100 Mbps Ethernet/IP port for peer-to-peer messaging. Programming is achieved using the Windows®-based RSLogix™ 500 software from Rockwell Automation.

TOPIC COVERAGE (3240-20 Only)

Basic Principles

- Familiarization with the PLC Trainer and RSLogix 500
- Programming Basics
- Online Operations
- Latching Instructions
- Timer Instructions
- Counter Instructions
- Sequencer Instructions
- Comparison Instructions
- Shift Register Instructions/The Force Function

Applications

- Mechanical Process Simulator
- Controlling a Line Welding System with a PLC
- Controlling an Automatic Component Insertion Machine with a PLC
- Designing a PLC-Controlled Automated System
- Introduction to the P-SIM Simulation Software
- Controlling a Traffic Light System with a PLC
- Controlling a Filling Line with a PLC
- Controlling a Batch Mixing Process
- Electro-Pneumatic System
- Electro-Mechanical System – DC Motor
- Electro-Mechanical System – Stepper Motor
- Wind Turbine System (requires Model 3244-20 Analog Expansion Kit to perform all exercises)
- Bottling Process System



Model 3240-20



Model 3240-A0

FEATURES (3240-20 Only)

- Allen-Bradley Micrologix™ 1200 PLC
- 12 Fault switches for troubleshooting
- 14 dual-voltage PLC inputs
- Seven PLC input switches (toggle-and push button-type)
- Ten dual-voltage PLC outputs
- Expansion spacing for the addition of an optional analog input/output module
- RS-232 DF1 full-duplex communication link between the PLC and RSLogix
- Circuit-breaker protected

FEATURES (3240-A0 Only)

- Built-in 10/100 Mbps Ethernet/IP port for peer-to-peer messaging
- Embedded Web server and LCD screen
- Online editing functionality
- Digital and Analog I/Os; Digital (24 VDC): 10 inputs (one 40kHz high-speed), six outputs (two 40 kHz highspeed); Analog (0 - 10 VDC): two inputs
- PID Capability
- Five push-button and five toggle switches
- 24 VDC built-in power supply
- Easy expansion using rackless I/O modules
- Onboard traffic light simulator
- Compatibility with MicroLogix and SLC instruction set
- Requires the RSLogix 500 programming software (Model 3245-A) and programming cable (3246-40)

Applications (3240-A0)

- Electro-Pneumatic System
- Electro-Mechanical System – DC Motor
- Electro-Mechanical System – Stepper Motor
- Wind Turbine System
- Bottling Process System

PLC CONTROLLER (PLC) TRAINING SYSTEMS

**Model 3270-40****Model 3270-50****Model 3270-60**

Three models of Programmable Logic Controller are available as options for control of the Lab-Volt Hydraulics Training System and various PLC applications. These models are the Lab-Volt Model 3270-40 (Allen-Bradley MicroLogix 1000), 3270-50 (Omron CPM1A), and 3270-60 (Siemens SIMATIC S7-222).

Each model comes mounted on a metal base which allows it to be clamped onto the perforated work surface of the Hydraulics Training System. Each PLC has the capacity to accept at least eight 24-Vdc input signals from input elements, such as push buttons, limit switches, magnetic switches, and photoelectric switches. Each model has the capacity to control at least six 24-Vdc output devices, such as pilot lamps and directional valve solenoids. All PLC inputs and outputs have been terminated with banana jacks for ease of system setup. An external 24-Vdc voltage source is required for powering the PLC and its internal output relays. This can easily be supplied by the Hydraulics Training System 24-Vdc power supply. Programming can be achieved using a computer software. The PLC unit is also compatible with the PLC Simulation Software (P-SIM 2000).

FEATURES (3270-40)

- Compact design
- Digital I/Os: 10 inputs (24 VDC), six outputs (Relay - 24 VDC)
- No possible expansion
- No PID Control
- Form-factor compatible with the Hydraulic/Pneumatic perforated work surfaces and the 8036 Industrial Controls workstations
- Compatibility with MicroLogix and SLC instruction set
- Requires the RSLogix 500 programming software (Model 3245-A) and programming cable (3246-40)
- Used with Hydraulic and Pneumatic Systems, Models

6080 and 6081; includes curriculum

FEATURES (3270-50)

- Compact design
- Digital I/Os; 12 inputs (24 VDC), eight outputs (Relay - 24 VDC)
- No possible expansion
- Requires a 24 VDC power supply (Model 6360)
- Requires CX Programmer programming software (Model 3245-20) and programming cable (Model 3246-20)
- Form-factor compatible with the Hydraulic/Pneumatic perforated work surfaces and the 8036 Industrial Controls workstations
- Used with Hydraulic and Pneumatic Systems, Models 6080 and 6081; includes curriculum

FEATURES (3270-60)

- Compact design
- Digital I/Os: eight inputs (24 VDC) six outputs (Transistor - 24 VDC)
- Requires a 24 VDC power supply (Model 6360)
- Fully configurable, integrated PID controller
- Form-factor compatible with the Hydraulic/Pneumatic perforated work surfaces and the 8036 Industrial Controls workstations
- Requires STEP7 Micro/Win programming software (Model 3245-30) and programming cable (Model 3246-30)
- Used with Hydraulic and Pneumatic Systems, Models 6080 and 6081; includes curriculum

Applications (All Models)

- P-SIM 2000
- Electro-Pneumatic System
- Electro-Mechanical System – DC Motor
- Electro-Mechanical System – Stepper Motor
- Process Control System (partial curriculum coverage only)
- Bottling Process System (partial curriculum coverage only)
- Traffic Light System (partial curriculum coverage only)

The powerful Model 5930 PLC, from the Allen-Bradley CompactLogix family, is used with the 5901 Flexible Manufacturing System (includes curriculum) and comes with 16 inputs and 16 outputs hard-wired to both banana jacks and terminal blocks on the module front panel. Banana jacks provide an easy and fast way to wire a setup, while terminal blocks allow students to wire their setup in a way much closer to what is commonly found in the industry.

An integrated DC power supply provides a constant 24-Vdc voltage with a maximum of 2.7 A to connect external devices. This PLC supports three types of network communication: DF1 Full-Duplex Serial link (RS-232-C), EtherNet/IP, and DeviceNet. The ports for serial and EtherNet/IP communication are located on the PLC processor while the DeviceNet communication port is available on the DeviceNet Scanner module. The PLC can be programmed using four languages: Relay ladder, structured text, sequential function chart, and function block diagram. Two DeviceNet cables are also provided. This module has eight switches that the instructor can use to insert faults. More Input/Output (I/O) points can be added to the PLC if required.

The Model 3128 PLC is used with the 8036 Industrial Controls System (includes curriculum) and consists of a small controller programmed in ladder logic with eight inputs (24 Vdc and four relay outputs). The programming is done using the LCD screen and the keypad on the controller or using the programming software (Easy-Soft) and cable included in this model. Electrical connections can be made using either the banana jacks or the terminal blocks.

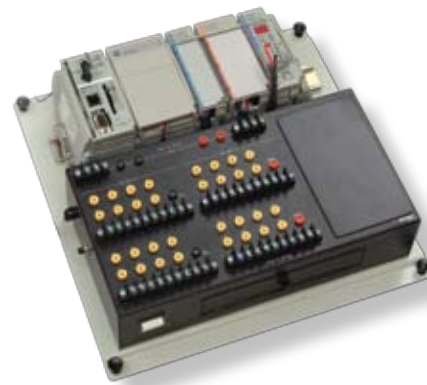

Model 5930



Model 3128

FEATURES (5930 Only)

- Used with 5901 Flexible Manufacturing System; includes curriculum
- Familiarization with the PLC Trainer and RSLogix 500
- Digital I/Os: 16 inputs (24 VDC), 16 outputs (Relay - 24 VDC)
- Built-in 24 VDC power supply
- Eight fault switches
- PID Capability
- Easy expansion using rackless I/O modules
- Can be programmed using four languages: Relay ladder, structured text, sequential function chart, and function block diagram
- Supports three types of network communications: DF1 Full Duplex Serial Link (RS-232-C), Ethernet/IP, and DeviceNet

- Requires RSLogix 5000 Lite Edition programming software (Model 5935) and a standard RJ45 cable

FEATURES (3128 Only)

- Used with 8036 Industrial Controls System; includes curriculum
- Compact design
- Digital I/Os: eight inputs (24 VDC), four outputs (Relay - 24 VDC)
- LCD Display
- Two of the eight digital inputs can be configured as 0-10 VDC analog inputs
- Requires a 24 VDC power supply (Model 3139)
- Form-factor compatible with the 8036 Industrial Controls workstations
- Includes EASY-SOFT Basic programming software and programming cable

Model 8075-1



Traffic Light System Model 8075-1

- Compatible PLCs: 3240-20; 3270-40; 3270-50; 3270-60
- A well-known classic training system
- N-S/E-W traffic control with pedestrian crossing (optional second Traffic Light model required)
- Another unit can be added to create a full, four-directions traffic light
- Flow management with proximity detectors (optional)
- Traffic light synchronization
- Fault insertion
- LEDs (long life)
- 10 24 VDC control inputs
- Includes job sheets

Model 8075-2



Electro-Pneumatic System Model 8075-2

- Compatible PLCs: 3240-20; 3240-A0; 3270-40; 3270-50; 3270-60
- Two double-acting cylinders
- Two reed switches and mechanical limit switch for PLC feedback
- Perforated work surface
- Control valve station featuring single- and double-solenoid valves
- Applications: Stamping, hold and punch, filling process, etc.
- Fault insertion
- Accepts three 24 VDC control signals from PLC
- Includes job sheets

Model 8075-3

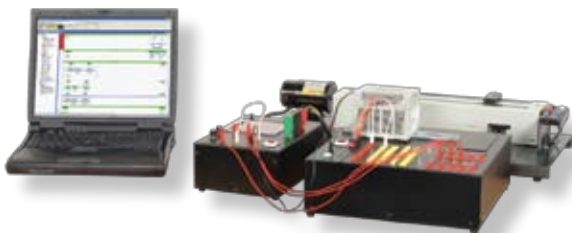

Electro-Mechanical System (DC Motor) Model 8075-3

- Compatible PLCs: 3240-20; 3240-A0; 3270-40; 3270-50; 3270-60
- Explores drives and lead screw positioning systems used in motion processes
- Industrial 1800 RPM, 90 VDC motor
- Two magnetic limit switches for PLC feedback
- Bi-directional, regenerative DC drive
- Perforated base to accommodate optional sensors
- Fault insertion
- Optional 100 ppr Optical Encoder
- Accepts three 24 VDC control signals from PLC
- Includes job sheets

Model 8075-4



Electro-Mechanical System (Stepper Motor) Model 8075-4

- Compatible PLCs: 3240-20; 3240-A0; 3270-40; 3270-50; 3270-60
- High-torque stepper motor
- Stepper motor drive programmed by computer using manufacturer software
- Programmable stepper motor drive
- Motion sequences triggered by the PLC I/Os
- Lead screw mechanism
- Two magnetic limit switches for PLC feedback
- DC power supply
- Perforated base to accommodate optional sensors
- Fault insertion
- Optional 100 ppr Optical Encoder
- Accepts eight 24 VDC control signals from PLC
- Includes job sheets

Model 8075-5



Wind Turbine System Model 8075-5

- Compatible PLCs: 3240-20 & 3244-20; 3240-A0
- System comprised of a Lab-Volt Nacelle Simulator – Model 3297 and a Wind Generator – Model 3213
- Small blower for generating air flow
- Nacelle equipped with DC motor and Mechanical clutch
- Two limit switches with NO and NC contacts
- Analog position sensor measures wind direction (0 - 10 V)
- Frequency variable pulse train signal measures wind speed (24 VDC)
- Requires external 24 V Power Supply
- Accepts two 24 VDC control signals from PLC for motor operation
- Includes job sheets

Model 8075-6



Level Process Control System Model 8075-6

- Compatible PLCs: 3240-20
- Submersible variable speed pump
- Level process column
- Electronic level process Interface
- Float switch
- Capacitive level switch
- Magnetic level switch
- Solenoid valve
- Manual valve
- Optional analog level sensor
- Self-regulating process allows a variety of PLC control schemes
- Explore batch and PID control (dependent on PLC specifications)
- Includes job sheets

Model 8075-7

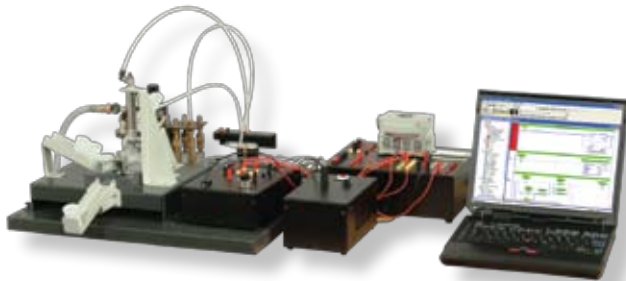

Bottling Process System Model 8075-7

- Compatible PLCs: 3240-A0
- Film canister capping process
- Compact application combines pneumatics, motion control, and PLC sequencing
- Two high-torque stepper motors
- Dual stepper motor drive
- Inductive proximity switch
- Mechanical switch
- Single solenoid
- Double-acting cylinder
- DC power supply
- Perforated work surface
- Dual stepper motor drive can be used as a Step/Dir or Jog/Dir drive
- Optional accessories allow containers to be filled with liquid during process
- Includes job sheets

Model 3245



RSLogix 500 Programming Software, Model 3245

The RSLogix 500 Programming software, Model 3245, is a Windows®-based application, produced by Rockwell Software, that allows the PLC to be programmed using a PC-type computer. The free-form ladder of RSLogix 500 allows students to concentrate on the application logic rather than on using the proper syntax when editing programs.

Several other features of RSLogix 500, such as a powerful project verifier, drag-and-drop editing, and search-and-replace functions, greatly facilitate PLC programming. The PLC can be programmed via the built-in RS-232 port on the PLC processor. This software comes with RSLinx™ which provides connectivity between the PLC and the PC-type computer.

SOFTWARE (P-SIM 2000)

P-SIM demonstrates the programming and operation of an actual programmable logic controller (PLC). The functionality of P-SIM is representative of current trends employed by PLC manufacturers.

Upon completion of the P-SIM 2000 course, students will understand and will be able to program basic relay inputs, output instructions, counters, timer circuits, compare functions, and debugging procedures.

In order to proceed with P-SIM 2000, students must demonstrate an understanding of basic relay logic control.

PLC SIMULATION SOFTWARE (P-SIM 2000) Model 91773

The P-SIM 2000 software enables a Windows-based computer to act as a process simulator when demonstrating PLC operations. A built-in ladder logic program editor allows students to create, test and debug industry-standard ladder logic programs to control animated processes. The simulated PLC includes the five basic input and output instructions, counters, timers, and compare function blocks. It also incorporates logical AND/OR operations in PLC programs by means of branching.

Typical processes, such as batch mixing and material transfer, are graphically displayed as animations, which respond to changes to the ladder logic program in the same manner that actual process equipment would respond.

With the optional P-SIM to PLC Interface, Model 3243, or Programmable Logic Controller, Model 3270, students can write programs to control the on-screen P-SIM simulations.

P-SIM I/O INTERFACE

PLC programming may be taught and practiced using the built-in ladder logic program editor or, with the P-SIM I/O interface, any PLC can be easily connected by using industry-standard 24 Vdc I/O. The PLC is then programmed to control the simulations within the P-SIM program.

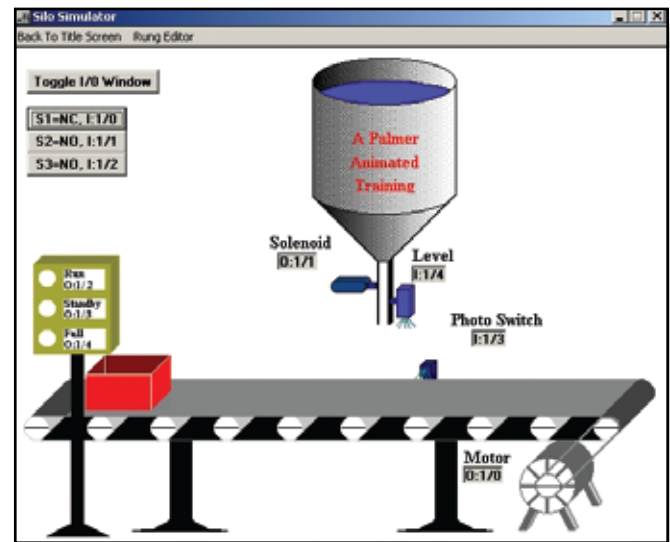

TOPIC COVERAGE

Model 91826

- Introduction to the PLC
- Introduction to Ladder Logic
- “AND” Normally Open Contacts
- “OR” Normally Open Contacts
- Normally Open/Normally Closed Contacts
- Interlocked Logic
- Lock-in Using Momentary Contacts
- On-Delay Time
- Traffic Light Logic
- Counter Application

Model 91773

- Familiarization with P-SIM 2000
- Rung Editor
- Basic Input/Output PLC Instructions
- Branching
- Timer and Counter PLC Instructions
- Comparison PLC Instructions
- Silo Simulation
- Batch Mixer Simulation
- Traffic Lights Simulation
- I/O Simulation

Large and Mid-Sized Robots For Heavy and Light Automated Tasks

The Lab-Volt Automation robots are powerful, precision-built, articulated arm, 5-axes micro robots designed in every way to emulate industrial robots in their programming and operating features. The Lab-Volt Robots, Models 5100 and 5150, are similar. However, the Model 5100 is controlled by a hand-held Teach Pendant, while the Model 5150 is controlled by a PC host computer. The Servo Robot, Model 5250, is controlled by either a hand-held Teach Pendant or by a PC host computer.

Through the curriculum and hands-on exercises, students learn to create automated workcells ideal for flexible manufacturing systems (FMS) and computer integrated manufacturing (CIM).

Models 5100 and 5150 are driven by six stepper motors. They have a 432-mm (17-in) reach, 0.45-kg (16-oz) load capacity, and a 3.2-mm (0.125-in) resolution. The 5100 controller is equipped with a serial port to connect to a personal computer for uploading and downloading programs using the File Transfer software.

The larger robot, Model 5250, is driven by six DC servo motors and can operate within a maximum radius of 732 mm (28.5 in). It has a 1.4-kg (3-lb) load capacity and weighs 20.4 kg (45 lb). The controller is a microprocessor based unit with 4 MB RAM and a floppy disk drive for saving task/point programs. The hand-held Teach Pendant has a four-line, 20-character LCD display, and a 40-key membrane keypad for manual control. A serial communication port is used to connect the robot controller to a host computer for remote operation and task editing with the host software.

An extensive list of optional equipment is available for the robots to accommodate a variety of teaching objectives. Equipment comprising a variety of feed mechanisms and conveyors enables students to set up workcells for computer-integrated manufacturing (CIM) or flexible manufacturing systems (FMS). All components are provided with location devices that allow a setup to be repeated when needed.

The robots feature advanced capabilities that distinguish them as high-precision, industrial quality systems, ideal for training in state-of-the-art manufacturing technology.



ROBOT SOFTWARE

The Teach Pendant-Controlled Robot System, Model 5100, comes with the File Transfer software that enables students to download and upload programs created with the Teach Pendant. The RoboCIM software for the Computer-Controlled Robot System, Model 5150, allows the robot to be directly controlled from the computer. This software provides a real-time 3D simulation of the robot and its immediate environment. Through an intuitive drag-and-drop interface, users can directly control the position and movement of the robotic arm.

RoboCIM Software

Menu-Driven Software for the Servo Robot

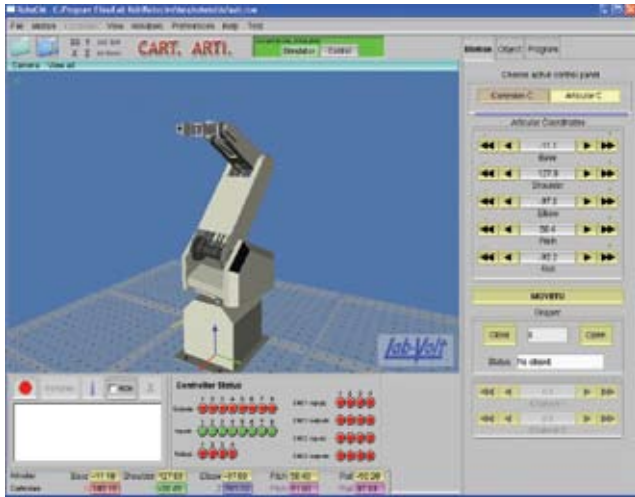

RoboCIM is a software used to simulate and control the operation of the Servo Robot System, Model 5250, and external devices such as a gravity feeder and a linear slide. The software is also used to create programs. In RoboCIM, the actual equipment is replaced with three dimensional-images. Sophisticated mathematical models accurately simulate the mechanical and electrical characteristics of the equipment.

One of the RoboCIM characteristics is to control and to visualize the motion of the system interactively. Two types of motion are available: joint motion and Cartesian motion.

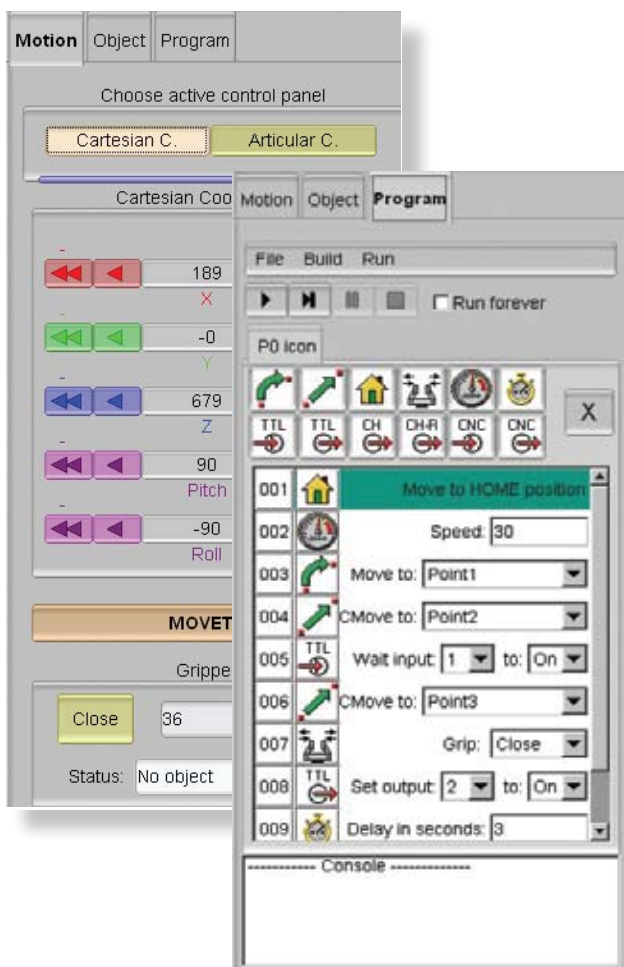

ROBOCIM SOFTWARE FEATURES

- Easy to use menu-driven software
- Simulation and control modes
- 3 dimensional (3D) virtual environment
- 7 predefined layout/camera view settings
- Control the movements of the Servo Robot using “articular” and “Cartesian” coordinates
- Programming without actual equipment
- Point recorder panel to easily record, rename, inform, hide, and delete points
- Create and run simple task programs using icons and graphical tools (no typewriting required)
- Create and run simple and complex task programs by typewriting all necessary commands
- Powerful set of task commands such as: Delay, DO-Until, If-Else, Gosub, Home, Input, Output, While-Repeat, and many others.

CNC Lathes and Mills

Offering Flexibility, Variety, Safety and Accuracy



The skills required to perform simple to more sophisticated Computer Numerical Controlled (CNC) turning and milling tasks are the focus of the Lab-Volt Automation lathes and mills. All of these machines share many features that contribute to a superior CNC training system.

Each machine has an on-board microprocessor that stores downloaded part programs, thereby eliminating the need for a dedicated computer for operation. The easy-to-use membrane keypad enables students to operate and control the machine by simply pressing buttons on the control panel.

Each machine connects directly to an Ethernet or RS-232 port of a personal computer to provide simultaneous programming and parts processing.

Each machine can be programmed using the Lab-Volt CNC Lathe/Mill software and CAD/CAM software.

The CNC Lathes and Mills, Models 5300, 5400, 5500, and 5600, are designed to support low-voltage communications with robotic units and accessories to create automated workcells ideal for flexible manufacturing systems (FMS) and computer integrated manufacturing (CIM). In addition, they feature TTL connectors for communication to an automation workcell. The TTL I/O and solenoid driver connectors are supported through the standard software. Also, on the rear or side panel are the main power switch and fuses for easy maintenance, and the serial and Ethernet ports for downloading part programs.

CONTROL PANEL FEATURES

- Key-released emergency stop push-button
- Ability to restart programs from stopping point after a

safety interruption

- 20-character by four-line LCD display
- Manual mode controls for:
 - X-and Z-Axis positions on lathes; X-, Y- and Z-axis positions on mills
 - Feed rate override
 - Spindle speed override
 - Tool change
 - TTL and solenoid outputs
 - Machine setup
- During execution, display of:
 - X and Z positions on lathes; X-, Y-and Z-axis positions on mills
 - Feed rate
 - Spindle Speed
 - Tool change
 - Current G & M codes
 - TTL outputs status on lathes and mills
- Stall light indicator/push-button abort key

SAFETY FEATURES

- Full cover over bed and work area
- Key-released emergency stop push-button
- Sensor switches monitored by the machine for:
 - Safety cover open
 - Tool post too close to chuck
 - Protection from over-travel on all axes
- Ability to restart programs from stopping point after operator abort or safety interruption

While these machines do not require a dedicated computer for operation, they do require an external computer for creating and downloading the part programs.

Lab-Volt CNC Lathe/Mill Software

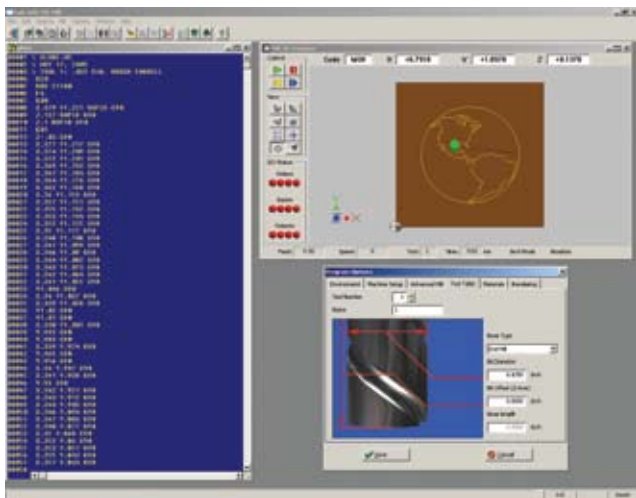
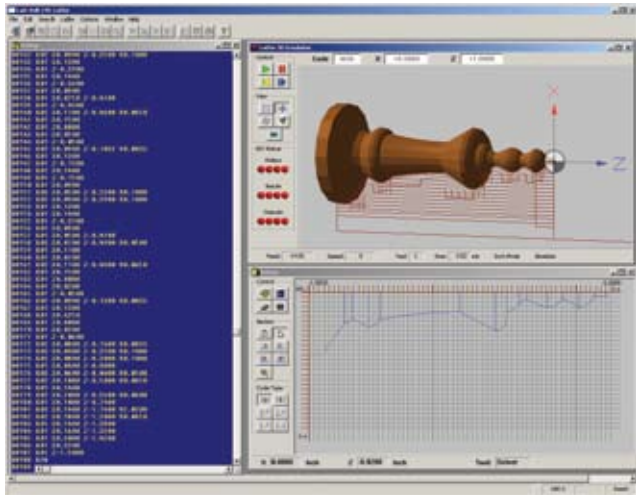
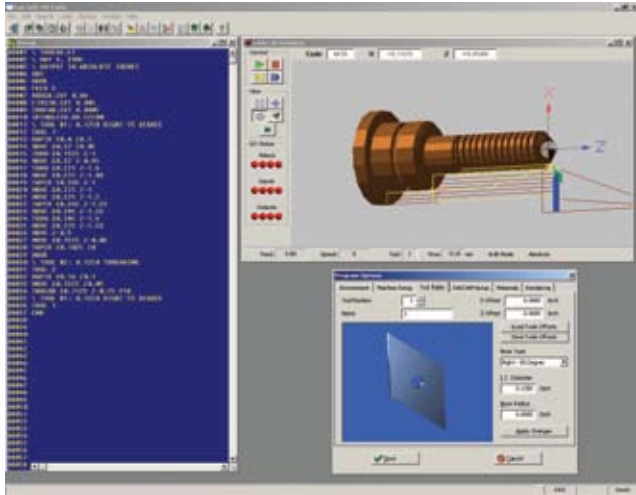

Enhances Instruction with Advanced Graphics and Editing Features

Lab-Volt CNC Lathe/Mill software is a Windows®-based, 32-bit application with the standard look and feel of the Windows® 98, Windows® 2000, Windows® ME, Windows® XP, and Windows® Vista operating systems. The software features a parametric-based graphical tool editor, 3D wireframe Tool Path Emulator with tool conflict view, a wizard-style part program creation mode, and standard Windows® interface.

Lab-Volt CNC Lathe/Mill software is compatible with G & M part programs, which can be imported from Computer-Aided Manufacturing (CAM) programs that support the EIA standard G & M codes. The software is supported by a complete curriculum, which includes teacher and student manuals, worksheets, course materials, and sample stock for milling and turning.

LAB-VOLT CNC LATHE/MILL SOFTWARE FEATURES

- EIA-274-D standard G and M code programming
- Parametric, graphical view tool editor with support for 20 tools
- Full G and M code help with graphical display
- Loading and saving tool offsets capability for the lathes
- Editable material database with load and save features
- Full 3D tool path emulator with wireframe user-defined 3D perspective
- Wizard-style block part editor
- Selection of basic G & M codes from a drop-down list
- AutoCAD .dxf file format import for the mills
- Simple CAD/CAM graphical development of part programs for the lathes
- Integrated CIM/FMS cell support options and commands
- Serial and Ethernet download capabilities for the Lab-Volt Automation CNC lathes and mills
- Support for custom machine configurations

Lab-Volt CNC Lathe/Mill Software enlivens CNC programming with colorful graphics and quick-paced navigation

Fabricus Software

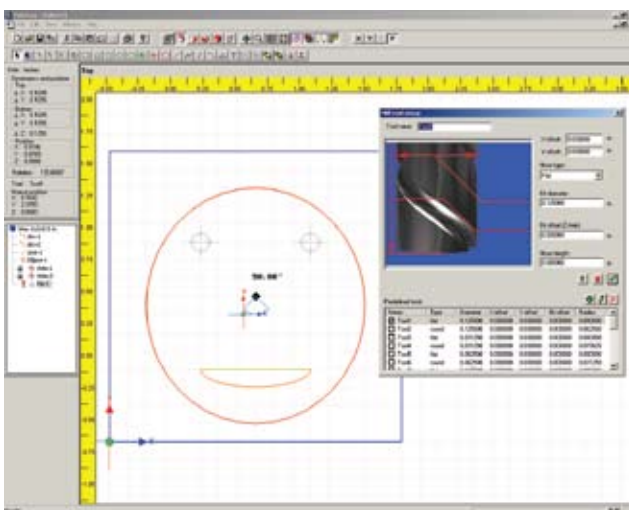
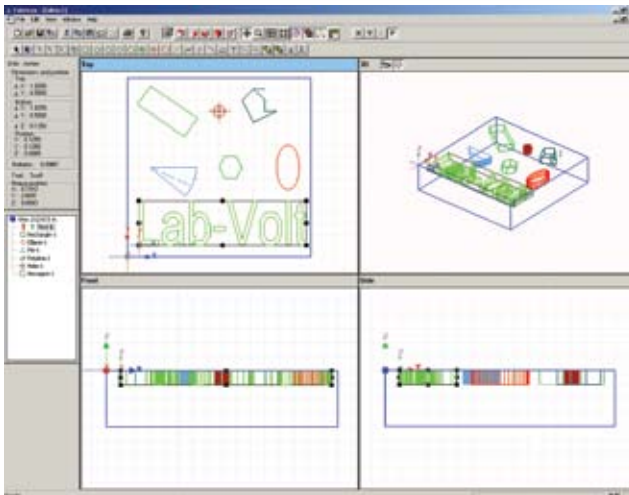
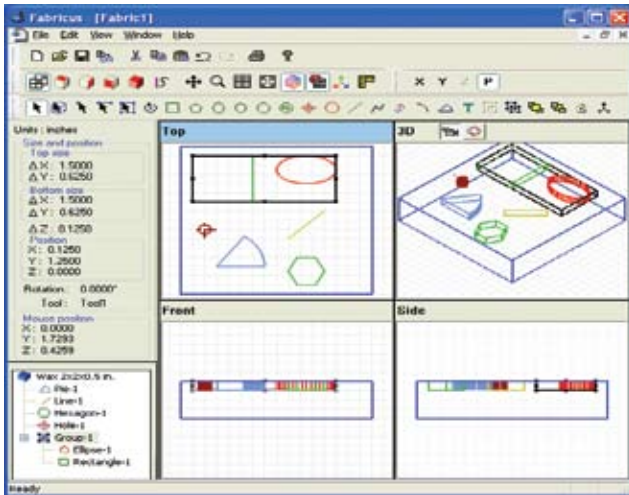

Easy-to-Use CAD/CAM Software

Fabricus is an entry level CAD/CAM software program used to easily create G & M code files. The generated codes are then used by CNC devices to repeatedly manufacture complex parts.

FABRICUS SOFTWARE FEATURES

- Direct interface to Lab-Volt CNC Lathe/Mill Software
- Simultaneously displays 4 screen views: top, front, right side and 3D. Can display any view in full screen. Zoom in and out, selection zooming, panning, fit to window and camera rotation (in 3D)
- Shows tool path & PRZ position
- Predefined stock selection or custom sizing
- Defined geometries include: rectangles, pentagons, hexagons, heptagons, octagons, other polygons (up to 20 sides), holes, ellipses, lines, polylines, Bezier curves, arcs, pies
- Chamfers
- Draws pocket, grooves, ellipse cups and islands
- Outputs G & M code programs
- Program feed, speed and increments
- Mouse position, shape position, rotation angle, tool and dimensions in a convenient toolbar
- A tree list of all the shapes present in the stock identified by names and icons and selectable for setting properties
- Validation of tool paths given a tool diameter
- Multiple document interface: work on more than one stock at a time
- Geometry right-click menu for most used commands
- Limit movement to x, y or z axes
- Shapes locking to prevent accidental movement
- 20 predefined tools and possibility to add more
- Two predefined milling machines and possibility to add more

CAD/CAM Software for Mill and Lathe

Integrated, Industrial-Grade Software for Computer-Aided Design and Computer-Aided Manufacturing

CAD/CAM Software is a fully integrated, industrial grade software package that makes it easy to teach, learn, and use Computer-Aided-Design (CAD) and Computer-Aided Manufacturing (CAM) programs. CAD/CAM Software features colorful, graphical icons and dialogue boxes that make commands visual and intuitive. It has DXF and IGES translators that make it possible to use geometry from other CAD programs.

CAD/CAM Software has extremely powerful editing tools for both CAD and CAM. As an integrated software package, CAD/CAM Software does not require students to switch back and forth between CAD and CAM applications. Both are available from the same screen menus.

CAD/CAM SOFTWARE GEOMETRY EXPERT

Geometry Expert allows geometry creations by both freehand and spreadsheet methods. With a full set of geometry editing tools, parts can be created in either 2D or 3D. Geometry Expert supports many types of geometry, including NURBS splines. Text creating is easy and contains a rich set of tools for spacing, formatting, and placing text around arcs and circles.

Geometry Expert enables the student to perform facing, pocketing, drilling, contouring, swept, and tapers.

CAD/CAM SOFTWARE FOR MILL AND LATHE

CAD/CAM Software is an easy-to-use, extremely flexible and powerful program featuring editable tool and material libraries. Creating, redoing, and reordering tool paths are made simple with the use of icons, dialogue boxes, and simple drag-and-drop capabilities.

The software includes powerful real-time renderings of tool paths while displaying mill marks, with the result that very few bad parts are produced. Post-processors are available for all the popular educational and industrial CNC machines. Lathe processes include roughing, finishing, and threading.

FEATURES

- Industrial grade software
- Dynamic viewing of parts from any direction
- Part previewing
- English and metric units
- Multiple software platforms
- Estimated run times
- Object-based graphic interface

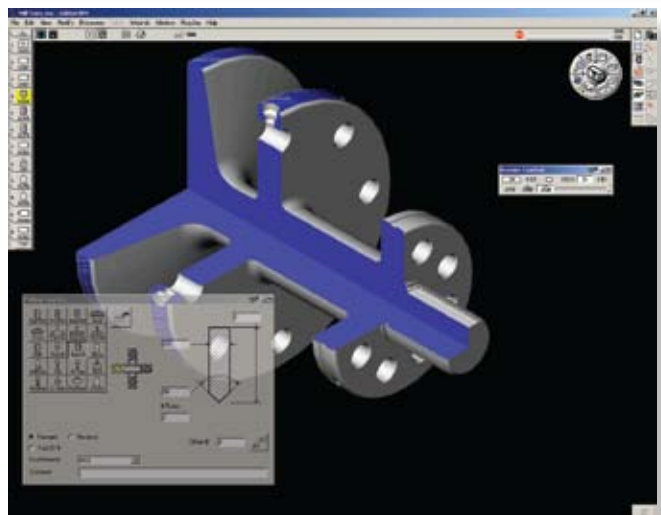
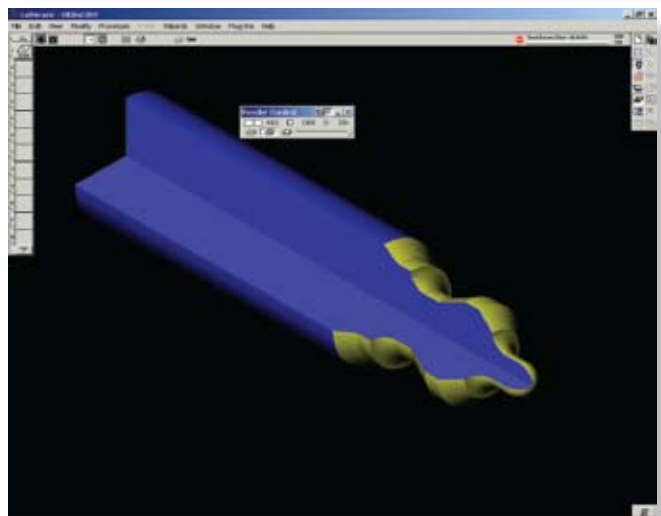
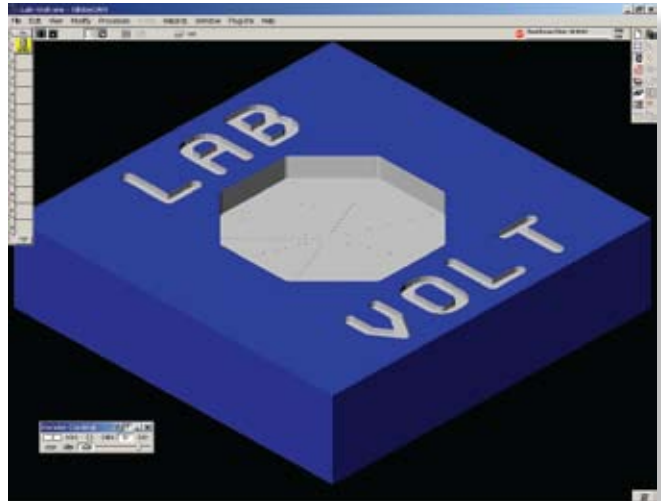

CAD/CAM Software brings CAD and CAM to life on the computer screen with vibrant images, high color, quick response, and easy controls.

The Teach Pendant- and Computer Controlled Robot Systems, Models 5100-20 and 5150-10, are low-cost solutions that provide a platform for training in the programming and operation of industrial-style robots. They are ideally suited for use in high schools, vocational schools, colleges, and universities.

The precision-built, articulated arm robot provides a scale version of modern industrial counterparts. A stepper motor, located in the base of the unit, provides horizontal rotation while five additional stepper motors, located in the shoulder, provide precision movement of the additional axes and end effector. The robot has five axes of rotational freedom plus a gripper and is able to move all axes simultaneously to perform a programmed move sequence. Movement of the elbow joint, wrist, and gripper mechanism is accomplished with cables and belts that link with a series of gears and belt-driven pulleys.

The base of the unit includes one connector for an external stepper motor, which can be used for further experimentation, such as operating the Rotary Carousel. The robot has four external TTL outputs and four TTL inputs located on the base. Additionally, there are four 12 Vdc solenoid outputs, one located in the shoulder and the remaining three in the base. The shoulder-mounted output is provided for controlling end tooling. The I/O capabilities can be used to allow the robot to interact with external hardware and conditions.

Four feedback switches provide the ability to locate a repeatable hard home position. The robot connects to a lightweight 12 Vdc switching power supply. A USB port interface on the robot base allows for direct control from a standard computer printer port.

ROBOT FEATURES

- Six stepper motor drives
- Two-finger gripper
- Power transferred from the stepper motor to the joints through mini HTP timing belts with anti-backlash design
- 432-mm (17-in) reach, 0.45-kg (16-oz) load capacity, 3.2-mm (0.125-in) resolution, and 6.4-kg (14.0 lb) unit weight
- Provided with push-lock fasteners for installation on perforated work surfaces
- Hard sided carrying case

TOPIC COVERAGE

- Introduction and Familiarization
- Programming
- Program Editing and Control Instructions
- Industrial Activity Simulation 1
- Industrial Activity Simulation 2
- Industrial Activity Simulation using a Belt Conveyor
- Industrial Activity Simulation using a Rotary Carousel
- Industrial Activity Simulation using a Gravity Feeder



TEACH PENDANT-CONTROLLED ROBOT SYSTEM MODEL 5100-20

The Teach Pendant-Controlled Robot System, Model 5100-20, is controlled by a teach pendant, which consists of a 24-key membrane hand-held keypad. It has a four-line, 20-character LCD display for feedback to the operator.



COMPUTER-CONTROLLED ROBOT SYSTEM MODEL 5150-10

The Computer-Controlled Robot System, Model 5150-10, includes the Robotus® software that allows the robot to be simulated offline and directly controlled from the computer. This software provides a real-time 3-D simulation of the robot. Through an intuitive drag and drop interface, users can control the position and movements of the robot. A mouse-driven graphical environment allows the user to create robot tasks consisting of point-to-point robot movement, input-and-output control, and simple logic decisions.

The Servo Robot System, Model 5250, provides complete training in the programming and operation of industrial robots. Through the curriculum and hands-on experience gained in working with the Model 5250, students learn to create automated workcells ideal for flexible manufacturing systems (FMS) and computer integrated manufacturing (CIM).

A precision-built, articulated-arm robot, Model 5250, has five axes of rotation and six servo drives with closed-loop control via optical encoders. The continuous path robot uses several joints simultaneously to perform a programmed move sequence controlled by the controller unit or a PC host computer.

Movement of the shoulder, upper arm, forearm, and wrist is accomplished with belts through a series of gears and belt-driven pulleys.

The controller unit is an embedded microprocessor with connections for inputs and outputs as well as a floppy disk drive for saving task/point programs. The hand-held teach pendant has a four-line, 20-character LCD display and a 40-key membrane keypad for manual control. A serial communication port is used to connect the 5250 controller to a host computer for remote operation and task editing with the host software.



- Boundary and current limit protection on all axes
- Push-lock fasteners for installation on perforated work surfaces

Robot Controller

- On-board microprocessor
- 8 TTL input ports, color coded, and LED status indicators
- 8 TTL output ports, color coded, and LED status indicators
- 4 relays, each provided with a set of normally open and normally closed contacts and LED status indicators
- Servo Robot and external motor release switch, and LED status indicator
- Floppy disk drive for program storage
- Hand-Held Terminal communication port

Safety Features

Key-Activated Emergency Stop Button module

RoboCIM Software

- Easy-to-use menu-driven software
- Direct keyboard control over all robot axes and functions
- Control output ports and read instruction channels
- Task commands include do, if-else, gosub, input, output, while-repeat conditions, and many others
- Point-to-point and task programming

TOPIC COVERAGE

- Introduction
- Familiarization with the Servo Robot System
- Point-to-Point Programs
- Task Programs
- Program Editing
- Control Overview
- Industrial Application Simulation Using a Gravity Feeder
- Industrial Application Simulation Using a Belt Conveyor
- Industrial Application Simulation Using a Pneumatic Feeder
- Industrial Application Simulation Using a Rotary Carousel
- Industrial Application Simulation Using a Linear Slide

FEATURES

Servo Robot

- High torque servo motors
- Steel and aluminum construction
- Timing belts for power transfer (enclosed for safety)
- Easily adjustable belt tension pulleys to maintain positional accuracy
- Oilite and UHMW (Ultra-High Molecular Weight) bushings for durability, minimum maintenance, and lubrication

ROBOTS

ROTARY CAROUSELS

Models 5208-10 and 5113-10

The Rotary Carousels demonstrate how parts can be transferred to and from the robot in a repetitive, rotational pattern. The Rotary Carousel, Model 5208-10, is driven by a DC servo motor and has a closed-loop feedback system and a limit switch feedback for hard home capabilities. The Rotary Carousel, Model 5113-10, is driven by a stepper motor. Model 5113 interfaces with the 5100 and 5150 robots, and Model 5208 interfaces with the 5250 robot.



ROTARY CAROUSEL
Model 5208-10



ROTARY CAROUSEL
Model 5113-10

BELT CONVEYORS

Models 5210 and 5118

Used in material handling experiments, the Lab-Volt Belt Conveyors can interface with the 5100-20, 5150-10 and 5250 robots, or they can be used as stand-alone units. The inputs enable the motor power, stepper motor clock signal, and the direction of the belt movement to be remotely controlled.



BELT CONVEYOR
Model 5210



BELT CONVEYOR
Model 5118

GRAVITY FEEDERS

Models 5119 and 5121

The Gravity Feeders are used in exercises that require square or cylindrical stock. They have sensor switches and feedback cables for connections to other devices. They interface with the 5100-20, 5150-10, and 5250 robots.



GRAVITY FEEDER
Model 5119



GRAVITY FEEDER
Model 5121

LINEAR SLIDE

Model 5209

The Linear Slide provides a track on which the 5250 robot can move to perform programmed tasks. The slide is driven by a DC servo motor, direct-coupled to a precision ballscrew. It has a closed-loop feedback system and a limit switch feedback for hard home capabilities. The slide is constructed of steel and has a precision ballscrew with a recirculating ball nut, guideways, and linear sealed bearings. It connects to either of the external motor ports on the rear of the 5250 Controller.



LINEAR SLIDE
Model 5209



PNEUMATIC FEEDER CONTROLLER
Model 5149

PNEUMATIC FEEDER CONTROLLER

Model 5149

The Pneumatic Feeder Controller is used to control the Pneumatic Feeders, Models 5122-1 and 5142-1. It includes a pneumatic valve, which supplies compressed air to the feeders. The operation of the Pneumatic Feeder Controller is controlled by limit switches in the feeder and storage sections of the Pneumatic Feeders.

PNEUMATIC FEEDERS

Models 5122-1 and 5142-1

The Pneumatic Feeders have micro-switch triggers to signal the Pneumatic Feeder Controller, which will activate the feeder to push a block into the receiving port once the previous block has been removed. Model 5122-1 feeds square stock and Model 5142-1 cylindrical stock to the 5100-20, 5150-10, and 5250 robots.



PNEUMATIC FEEDER
Model 5122-1



PNEUMATIC FEEDER
Model 5142-1

Lab-Volt offers many types of benches to set up and store equipment. They can be joined when extra space is required, and configured to accommodate a wide variety of space and teaching needs. They come in many sizes and are provided with heavy-duty, lockable casters.

The top of the benches consists in perforated work surfaces on which the components are mounted. Optional shelves, storage surfaces, dressing panels, and lockable doors can be added to the benches.

Mounting and removal of the components are especially easy with push-lock fasteners that snap effortlessly into the perforations of the work surfaces. Many Lab-Volt models are provided with location pins that fit into the perforations to locate the components with precision. This location system is very useful when a setup has to be repeated.



Model 46601-3



Model 46601-1



Model 46605-1



The CNC Lathe, Model 5300, is a mid-sized turning system that provides complete, safe, and affordable training in computer-aided manufacturing (CAM), and computer-numerical controlled (CNC) turning. The Lab-Volt curriculum gives students experience with industry-standard software and high-precision equipment designed to prepare them for jobs in manufacturing.

The 5300 CNC Lathe is a slant-bed lathe constructed with a machined high-grade alloy bed, headstock, and tailstock. Each axis on the Lab-Volt lathe is driven by its own DC stepper motor whose speed can be programmed from 0 to 36 cm/min (0 to 14 in/min). The spindle motor is programmable from 0-to 2800-r/min chuck speed.

The included Lab-Volt CNC Lathe software uses today's industry-standard G&M codes. The software features Tool Path Emulation and CAD/CAM design, which allow the programmer to make a drawing of a part, set up the tool paths and cut steps, create the part program, and simulate tool motion on a monitor to check the finished part prior to the actual cutting.

TOPIC COVERAGE

- History of CNC
- Identify Components of a CNC Lathe
- Safety
- Tool Movement
- Speed, Feed, and Cut Steps
- Lathe Program Codes
- The PRZ
- Lathe Setup
- On-Screen Emulation
- Turning a Part
- Input a Part Program
- Editing Commands
- CNC Programming
- Understanding and Using CAD/CAM
- Create a Part Using CAD/CAM Programming
- Careers in Turning



FEATURES

- Key-released emergency stop push-button
- Ability to restart programs from stopping point after safety interruption
- On-board embedded microprocessor
- Stand-alone manual mode operation
- Batch mode for independent operation or operation in CIM cells
- Software allowing the programming of up to 20 tools
- Tool post with HSS tool bit
- Three-jaw self-centering manufacturer-supplied recommended chuck
- Side panel with connectors for TTL communication with the 5250 robot, M-code supported solenoid drivers, connects to host computer through RS-232 or Ethernet port
- Lathe constructed with a machined high-grade alloy bed, headstock, and tailstock
- Each axis driven by its own DC stepper motor
- Programmable speeds from 0 to 36 cm/min (0 to 14 in/min)
- 1/3-HP, DC variable speed spindle motor
- Spindle motor programmable from 0- to 2800-r/min chuck speed

The CNC Lathe, Model 5500, is a heavy-duty, industrial-grade training system for computer-aided manufacturing (CAM), and computer-numerical controlled (CNC) turning. The 5500 CNC Lathe is constructed with heavy-duty cast-iron bed, headstock, and tailstock. The lathe features stepper motor drives with ribbed timing belts that operate recirculating anti-backlash ball screws on the X and Z axes, providing maximum positional accuracy. For ease of maintenance, telescoping helical covers protect the Z axis ballscrew.

Each axis on the 5500 CNC Lathe is driven by its own stepper motor, whose speed can be programmed from 0 to 76 cm/min (0 to 30 in/min). The spindle speed is also continuously variable from 0 to 3400 r/min and no belt or gear changes are required.

The included Lab-Volt CNC Lathe software uses today's industry-standard G&M codes. The software features Tool Path Emulation and CAD/CAM design, which allow the programmer to make a drawing of a part, set up the tool paths and cut steps, create the part program, and simulate tool motion on a monitor to check the finished part prior to the actual cutting.

TOPIC COVERAGE

- History of CNC
- Identify Components of a CNC Lathe
- Safety
- Tool Movement
- Speed, Feed, and Cut Steps
- Lathe Program Codes
- The PRZ
- Lathe Setup
- On-Screen Emulation
- Turning a Part
- Input a Part Program
- Editing Commands
- CNC Programming
- Understanding and Using CAD/CAM
- Create a Part Using CAD/CAM Programming
- Careers in Turning



FEATURES

- Key-released emergency stop push-button
- Ability to restart programs from stopping point after safety interruption
- On-board embedded microprocessor
- Using optical encoder feedback, the lathe is also capable of reading
- An optional 10-tool automatic tool changer is available
- Stand-alone manual mode operation
- Batch mode for independent operation or operation in CIM cells
- Software allowing the programming of up to 10 tools
- Tool post with HSS tool bit
- 1-HP constant torque DC spindle motor controlled from within the program
- Three-jaw self-centering manufacturer-supplied recommended chuck
- Rear panel with connectors for TTL communication with the 5250 robot, M-code supported solenoid drivers, connects to host computer through RS-232 or Ethernet port
- Main power indicator
- Heavy-duty DC spindle motor
- Cast iron chassis
- Recirculating anti-backlash industrial-grade ball nuts and screws on X and Z axes
- Magnetic safety interlock

OPTIONAL EQUIPMENT

- 10-Tool Automatic Tool Changer

The CNC Mill, Model 5400, is a state-of-the-art milling system that provides complete training in computer-aided manufacturing (CAM), and computer numerical controlled (CNC) milling.

The 5400 CNC Mill is built to support safe, low-voltage communications with robots and devices to create automated workcells ideal for flexible manufacturing systems (FMS). On the side panel of the mill are connectors for interacting to an automation workcell. A connector is provided for standard TTL I/O communications with robotics equipment. The TTL I/O and solenoid driver connectors are “M” code supported through the standard software supplied. Also on the side panel are the main power switch, and the serial and Ethernet ports for downloading programs.

Each of the mill’s three axes is driven by its own DC stepper motor which can be programmed from 0 to 36 cm/min (0 to 14 in/min) movement rates which meet the requirements of basic and advanced milling. The spindle speed is continuously variable and programmable to a range of 0 to 2800 r/min.

The included Lab-Volt CNC Mill software uses today’s industry standard G&M codes. The software features Tool Path Emulation so students can check the finished part prior to the actual cutting. The software is also capable of directly importing an AutoCAD.DXF file and the computer will automatically generate the codes to cut the drawing on the mill.

TOPIC COVERAGE

- History of CNC
- Identify Components of a CNC Mill
- Safety
- Speed, Feed, and Cut Steps
- Enter a Program into a Computer
- Identify and Operate Controls on a Mill
- Identify X, Y, and Z Axis Movements on a Mill
- Set-Up Controller and Mill to Machine a Part
- Machine a Part
- Write and Execute a Program to Mill a Shoulder and Drill a Hole
- Write and Execute a Program to Mill a Pocket
- Calculate and Program Cutter Clearances
- Combine Subroutine and Repeat Loop Operations to Machine a Complex Part
- Careers in CNC Machining



FEATURES

- Key-released emergency stop push-button
- Ability to restart programs from stopping point after safety interruption
- On-board embedded microprocessor
- Stand-alone manual mode operation
- Batch mode for independent operation or operation in CIM Cells
- Software allowing the programming of up to 20 tools
- Mill constructed with machined high-grade alloy bed and head stock
- 12-key membrane keypad with 20-character by 4-line LCD display
- Main power indicator
- Feed rate override
- Spindle speed override
- Stall indicator
- Removable side panel for access to robot
- Connects to host computer through RS-232 or Ethernet port

The CNC Mill, Model 5600, is a heavy-duty, state-of-the-art machining system consisting of a cast iron chassis with recirculating anti-backlash ball nuts and screws for lower maintenance and maximum position accuracy. The 5600 CNC Mill also features R8 tooling, which provides complete compatibility with industrial machine tools. With the 5600 CNC Mill, students can mill parts made of soft materials such as aluminum, mild steel, and brass. Training in the 5600 CNC Mill enables students to gain skills that are directly transferable to jobs in manufacturing.

Each of the mill's axes is driven by its own DC stepper motor which is programmable from 1 to 50 cm/min (1 to 20 in/min). The spindle speed is continuously variable and programmable to a range of 0 to 3400 r/min.

The included Lab-Volt CNC Mill software uses today's industry standard G&M codes. The software features Tool Path Emulation so students can check the finished part prior to the actual cutting. The software is also capable of directly importing an AutoCAD.DXF file and the computer will automatically generate the codes to cut the drawing on the mill.



TOPIC COVERAGE

- History of CNC
- Identify Components of a CNC Mill
- Safety
- Speed, Feed, and Cut Steps
- Enter a Program into a Computer
- Identify and Operate Controls on a Mill
- Identify X, Y, and Z Axis Movements on a Mill
- Set-Up Controller and Mill to Machine a Part
- Machine a Part
- Write and Execute a Program to Mill a Shoulder and Drill a Hole
- Write and Execute a Program to Mill a Pocket
- Calculate and Program Cutter Clearances
- Combine Subroutine and Repeat Loop Operations to Machine a Complex Part
- Program Controller to Cut a Groove, Machine a Pocket, and Drill a Hole
- Print a copy of a Part Program
- Load and Execute a Part Program
- Careers in CNC Machining

FEATURES

- Key-released emergency stop push-button
- Ability to restart programs from stopping point after safety interruption
- On-board embedded microprocessor
- Stand-alone manual mode operation
- Batch mode for independent operation or operation in CIM Cells
- Software allowing the programming of up to 20 tools
- Mill constructed with machined high-grade alloy bed and head stock
- 12-key membrane keypad with 20-character by 4-line LCD display
- Main power indicator
- Feed rate override
- Spindle speed override
- Stall indicator
- 1-HP motor
- Rear Panel Conversion for 5250 TTL Control
- Pneumatic Vise Output
- Connects to host computer through RS-232 or Ethernet port

INSTRUMENTATION AND PROCESS CONTROL

Sophisticated Training Systems for Measurement and Control of Flow, Level, Pressure, and Temperature

BENCH-TOP TRAINERS

Model 3521 and 3522

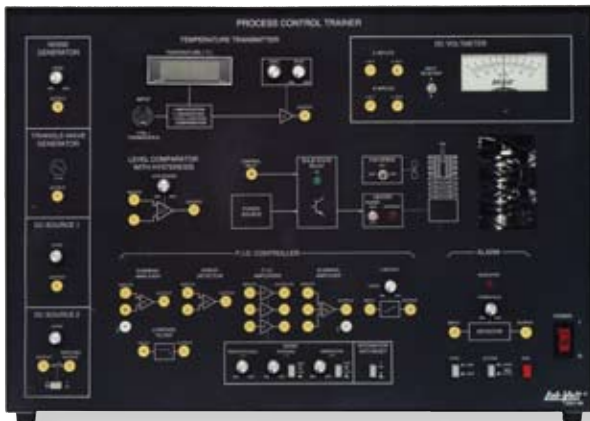

The Lab-Volt Process Control Trainer, Model 3521, is a bench-top portable trainer designed to familiarize students with the concepts related to process control systems, from basic definitions used in instrumentation and control to closed-loop control systems. Although a temperature process is involved with this trainer, the theory and concepts presented in the student manual can be applied to a variety of process control applications. The trainer includes DC sources, a PID controller, an alarm detector, and a noise source that allow studying various types of closed-loop control systems. A dual input voltmeter is provided to measure voltages in the process control system.

TOPIC COVERAGE

- Open-Loop Process Control
- Positive and Negative Feedback in Closed-Loop Process Control
- Basic Measurement Channel
- Basic Measurement Channel Instrument Characteristics
- Process Characteristics
- Two-Position Controller

- Proportional Controller
- Proportional Plus Integral Controller
- Proportional Plus Derivative Controller
- Proportional Plus Integral Plus Derivative Controller
- Alarms in Process Control Systems
- Troubleshooting

ESTIMATED PROGRAM HOURS

Open



The Temperature/Flow Process Training System, Model 3522, is a portable, bench-top unit designed to familiarize students with the fundamentals of instrumentation and process control. Advanced concepts such as cascade and feed-forward control can also be studied. The trainer provides a temperature process and a flow process. Process control is achieved through an external controller that is compatible with either standard 4-20 mA or 0-5 V signals.

TOPIC COVERAGE

- Familiarization with the Trainer
- Open-Loop Process Control
- Closed-Loop Process Control
- Measurement Channel Characteristics
- Process Characteristics
- Proportional (P) Control

- Proportional plus Integral (PI) Control
- Proportional plus Integral plus Derivative (PID) Control
- Open-Loop Tuning Method
- Ultimate-Cycle Tuning Method
- Troubleshooting Temperature and Flow Processes

ESTIMATED PROGRAM HOURS

Open

INSTRUMENTATION AND PROCESS CONTROL TRAINING SYSTEM

Series 3530



Shown with optional equipment

The Lab-Volt Instrumentation and Process Control Training System introduces students to process instruments and controls. The use of modern equipment coupled with a complete training program helps students to get the theoretical and practical knowledge that is mandatory to work in the process control industry.

The use of the latest control equipment coupled with a wet simulator and complete training curriculum helps students gain the theoretical and practical knowledge that is mandatory for employment in the process control industry. To maximize the educational efficiency of the system, the teaching material covers the industry standards for maintenance concurrently with the main training objectives. The modularity of the system allows the instructor to select the equipment depending the training objectives. Several configurations are available for a single workstation. Adding optional equipment can increase the number of these configurations.

The Instrumentation and Process Control Training System features two workstations: the Process Workstation and the Instru-

mentation Workstation. The equipment of the Pressure, Flow, and Level Process System is installed on both workstations. Two student teams can work at the same time on the workstations if the Second Team Add-On, Model 3530-A, is used. One controller of the 3539 Series is required for each team. A wide choice of optional equipment is available.

TOPIC COVERAGE

- Introduction to Process Control
- Pressure Processes
- Flow Processes
- Level Processes
- PID Process Control
- Introduction to Temperature Process Control
- Temperature Measurement
- Characterization of Temperature Process
- PID Control Temperature Processes

Instrumentation and Process Control Training System

Series 3530 (Continued)

Process Workstation*

The Process Workstation is a double-sided mobile workstation with a 115-liters (30-gal) tank, a centrifugal pump, a Rotameter, a Column (Large Diameter), a Drip Tray (Front), an Instrumentation Mounting Pipe, Ball Valves, and Process Supports. To have a fully functional system, a controller, Model 3539-XX, is required.

To configure the system for hands-on training, the students have to install the appropriate instruments as described in the student manuals. The student manuals cover both the theory and practice of measurement, control, and troubleshooting of pressure, flow, and level processes.

***Both stations shown with optional equipment.**

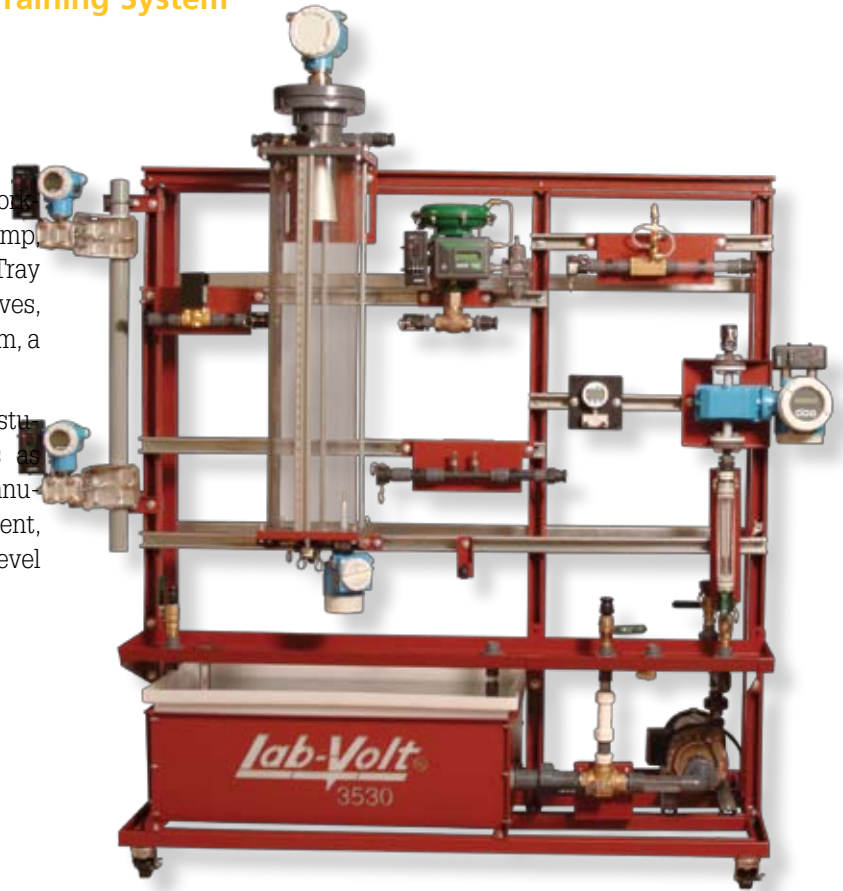

Instrumentation Workstation*

The Instrumentation Workstation is designed to house the Electrical Unit and the Pneumatic Unit as well as other electrical equipment. Devices such as controllers, PLC, Color Paperless Recorder, and Touch Screen Graphic Terminal must be installed on the Instrumentation Workstation. This prevents such equipment from coming in contact with water.

The Electrical Unit provides power for the whole system. It includes a lockable power switch, a variable speed drive, and a 24-Vdc power supply. The design of the Electrical Unit allows cutting both the electric and pneumatic power using either an emergency button or the lockable power switch.

The teaching material includes a complete lockout/tagout procedure explaining how to lock the power switch. This procedure is similar to the procedure used in the industry to lock and unlock electrical equipment.

Like the Process Workstation, the Instrumentation Workstation is a double-sided mobile workstation. Two groups of students can work at the same time on the system, one group on each side. The Instrumentation Workstation also features a storage cabinet with lockable doors and a shelf.



PROCESS CONTROL TRAINING SYSTEM

Model 6090



The Lab-Volt Process Control Training System, Series 6090, familiarizes students with the fundamentals of instrumentation and process control. It demonstrates the control of pressure, flow, level, temperature, and pH processes. It can also demonstrate advanced process control techniques, such as second-order control, and cascade control when used with a controller featuring these functions.

The basic trainer demonstrates PID (proportional, integral, derivative) control of flow, pressure, and level processes. It comes with a variable-speed pump, a tank, a column, two-way valves, pressure gauges, flexible hoses, a venturi tube, an orifice plate, a rotameter, a paddle wheel flow transmitter, and a differential pressure transmitter.

A work surface, consisting of a solid-metal perforated plate hinged to a drip tray, provides a large area (that can be laid flat or tilted to a 45E angle) on which components can be mounted. Additional work area can be added with the expanding work surface provided.

Mounting and removal of the components are made especially easy with push-lock fasteners that snap effortlessly into the perforations of the work surface. The components

can be interconnected by means of flexible hoses equipped with garden-type fittings that permit easy and fast component connections without the use of tools. The hose fittings contain check valves to prevent water from running out of the hoses when they are disconnected.

TOPIC COVERAGE

- Process Control Fundamentals Using the LVPROSIM Software
- Pressure, Flow, and Level Process Control
- Temperature Process Control
- pH Process Control

ESTIMATED PROGRAM HOURS

Pressure, Flow, & Level Process Control - 50 Hours
 Temperature Process Control - 30 Hours
 pH Process Control - 30 Hours

Process Control Training System

Model 6090 (Continued)



Model 6090-2



Model 6090-3

Although the equipment is designed to operate atop a regular work table, an optional bench is available to provide mobility and storage space. Mounted on four heavy-duty, swiveling, lockable castors, the bench provides a storage area for components. Optional dressing panels and lockable doors are also available to fully enclose and lock the bench.

The trainer processes can be controlled by a computer-based PID Controller through the use of a personal computer (Pentium type), the included Process Control and Simulation Software (LVPROSIM), Model 3674, and the I/O Interface, Model 9065. The trainer processes can also be controlled using any conventional PID controller compatible with standard 4-20 mA signals or 0-5 V signals.

To demonstrate PID control of temperature and pH processes, additional components can be added to the basic trainer. The additional components required for temperature process control include a heating unit, a cooling unit, and temperature transmitters. Those required for pH process control include chemical tanks, metering pumps, and a pH transmitter.

Cascade and second-order process control can also be studied on the basic trainer by having the students from two workstations work together at a single workstation, or by adding the following components to the basic trainer: a Pressure Transmitter, a Column, and a PID Controller.

FEATURES

- Modular design
- Pressure, flow, and level processes
- Optional sets of components are available to implement temperature process
- Designed for use with any PID controller compatible with either 4-20 mA or 0-5 V signals
- Work surface can be configured to accommodate a wide variety of space and training needs
- Components mount easily on the work surface through push-lock fasteners
- Easy component interconnection through flexible hoses terminated with quick-connect fittings
- Optional equipment (Models 3674 and 9065) provides interface with a computer for data acquisition and process control
- Optional workbench and dressing panels are available to provide the work surface with mobility and storage space
- Comprehensive courseware
- Cost-effective alternative to systems using industrial grade components

MOBILE INSTRUMENT & PROCESS CONTROL TRAINING SYSTEM**Model 3500-MO****Model 3501****Model 3503****Model 3502****Model 3504**

The Mobile Instrumentation and Process Control Training System, Model 3500-MO, is a series of self-contained mobile workstations that provide hands-on training in the measurement, control, and troubleshooting of Pressure, Flow, Level, Temperature, Heat Exchanger, and Analytic Process Loops.

Each workstation, which is constructed on a sturdy steel frame with casters, can operate independently or in combination configurations to simulate complex processes which simulate real-world time lag and process responses.

The course begins with the basic characteristics of the major process variables: pressure, flow, level, and temperature - and progresses to measurement devices and calibration of sensors, transducers, and transmitters. From there, students learn the principles and operation of the microprocessor-based controller and progress to the basics of closed loop control and methods of controller tuning.

FEATURES

- Fault-insertion capabilities
- Patch-connected signal conditioners, controllers, and transmitters to permit alternate control schemes and for flexibility in incorporating new technology as it is developed
- Realistic process response times
- Multi-element and ratio control capability
- Microprocessor-based controllers

- Comprehensive courseware

COMPRESSED AIR REQUIREMENT

700 kPa (100 psi) at 0,95 l/s (2 SCFM) of dry air to each station

COMPUTER CONTROL SYSTEM

- Supervisory Control and Data Acquisition (SCADA)
- Alarms
- Graphics

SYSTEM ENHANCEMENTS

- Calibration Station
- Computer Process Control Trainer
- Flow Elements - Flow and Level Stations
- Flow Assemblies - Flow Station

SYSTEM VOLTAGES

120, 220, 240 V - 50/60 Hz

PROCESS CONTROL STATIONS

Models 3505, 3507, 3508, and 3550



Model 3550

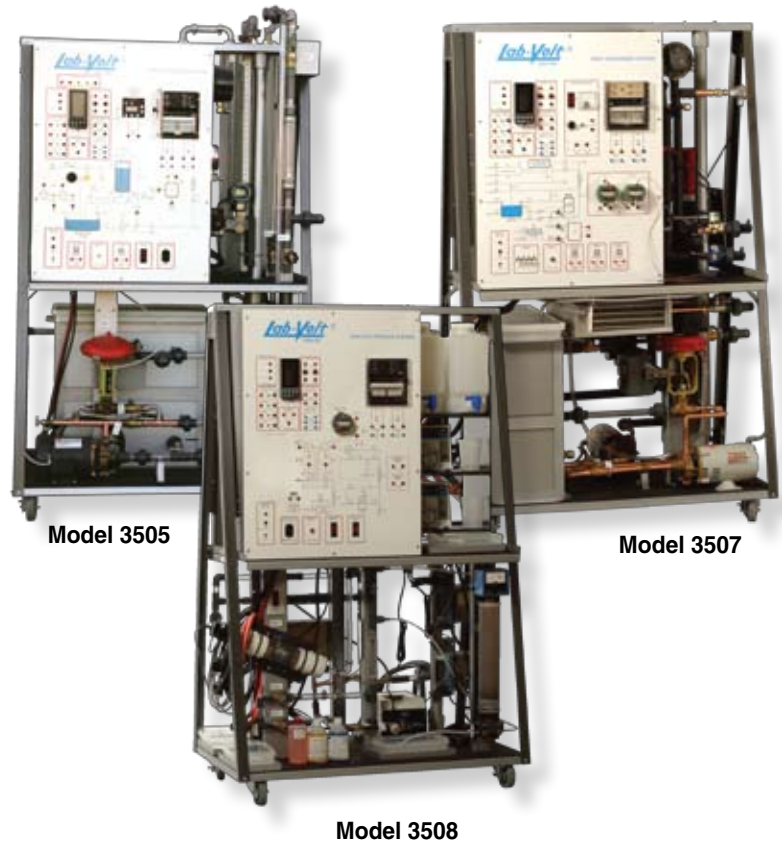

Model 3505

Model 3507

Model 3508

The Multi-Process Station, Model 3505, consists of a pump, a water reservoir, a programmable AC variable frequency pump drive, a 20-cm (8-in) diameter, 92-cm (36-in) high level column, a pneumatically operated flow control valve, needle valves, and process piping made of clear thermoplastic (PVC). The pump can be operated either at fixed speed or variable speed.

The Heat Exchanger Station, Model 3507, consists of two pumps, a water reservoir, a 6-kW (5.7-Btu/s) electric water heater, a shell-and-tube heat exchanger, a forced-air cooling-coil, a pneumatically operated flow control valve, a header, and needle valves.

The Analytic Process Station, Model 3508, is intended to be coupled to the Level Process Station, Model 3503, for the study of water quality monitoring, through the measurement of pH, conductivity, temperature, and dissolved oxygen. The station is made up of separate heating, demineralizer, sampling, chemical, dissolved oxygen sections.

The Calibration Bench, Model 3550, is designed for basic study of the operation and calibration of process instrumentation and is required to calibrate the pressure gauges, pressure transmitters, D/P transmitters, temperature transmitters, I/P converters, and strip chart recorders found on the Process Stations of the Mobile Instrumentation and Process Control Training System.

FEATURES

- All required gauges, switches, manometers, patch-cords, hoses, and flow elements are included
- Transparent piping and valves for student observation of system operation (where applicable)

ESTIMATED PROGRAM HOURS

Multi-Process Station - Open
 Heat Exchanger Station - Open
 Analytic Process Station - 21 Hours
 Instrumentation and Calibration Station - 15 Hours

LVPROSIM SIMULATION SOFTWARE Model 3674

The Lab-Volt LVPROSIM - Process Control and Simulation Software, Model 3674, provides computer-based training in generic process control and simulation of the Lab-Volt Model 3521 Process Control Trainer.

Using the LVPROSIM software, students can simulate a generic process with system configurations for adjustable process time constants, dead time, process gain, and disturbance time constant. At the same time, students can use the software to study and simulate process dynamics and regulation, which they can later apply with the Lab-Volt Model 3521 Process Control Trainer.

LVPROSIM offers a selection of preconfigured experiments for the generic process simulator, as well as for the 3521 Process Control Trainer simulator. The students can also design new experiments for the generic process simulator. A series of pre-programmed tests can be selected from the main menu. User-defined tests and experiments can also be created using the test generator and experiment creator, which can be password protected to limit access to the instructor.

TOPIC COVERAGE

- Introduction to process control
 - Closed-loop control
- Process dynamics
 - Reaction curve of a first-order process
 - Frequency response of a first-order process
 - Reaction curve of a second-order process
 - Frequency response of a second-order process
- Proportional plus integral control mode
 - Open-loop response of a PI controller
 - Frequency response of a PI controller
 - Proportional plus integral control
- Proportional plus derivative control mode
 - Open-loop response of a PD controller
 - Frequency response of a PD controller
- The PID controller
 - Open-loop response of a PID controller
 - Tuning of a PID controller

FEATURES

- Trend recorder
- PID (Proportional, Integral, Derivative) Controller
- Function Generator
- Test function
- Self-tuning
- FOPDT (First Order Plus Dead Time) modeling

COMPUTER REQUIREMENTS

- Pentium type
- Windows® 2000, Windows® XP, or Windows® Vista

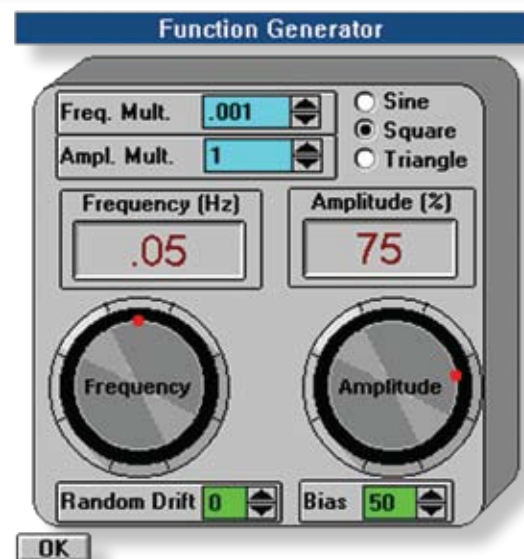
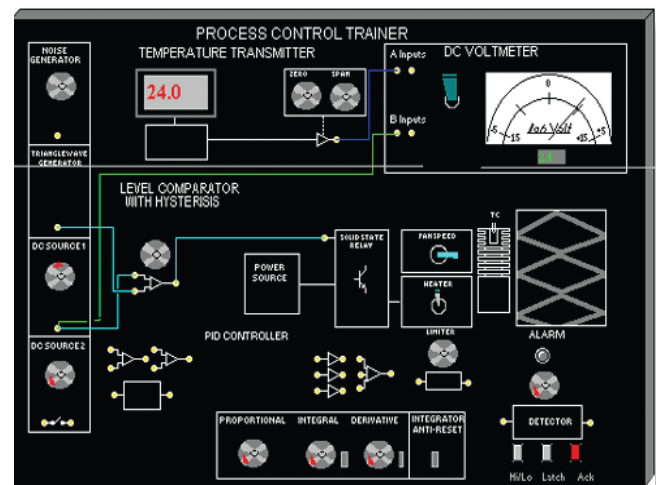
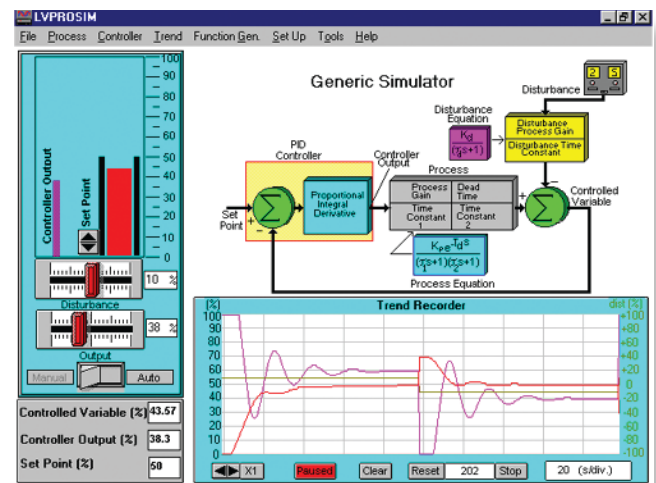

ESTIMATED PROGRAM HOURS

35 hours

LANGUAGE VARIATIONS

English

WEB-BASED INDUSTRIAL TRAINING

Delivering the Difference in Industrial Training with E-learning and CD-ROM-Based Courses

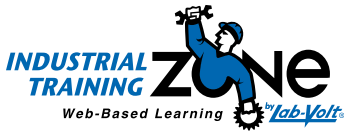

Industrial Training Zone by Lab-Volt delivers a broad range of online and CD-ROM-based fundamental and specialty industrial training courses designed to help instructors build a more competent, qualified, and efficient workforce.

Engaging training systems feature 3D simulations, course narrations, a virtual guide, testing, and quizzes to promote learning retention and use on the job.

Courses are available online or via CD-ROM. Each Online CoursePack™ contains one training pass (good for one student to take one course), an online reference manual, online assessment and certification passes, and a Toolbox™ user account. Each CD CoursePack™ contains a CD training perpetual license, course-specific CD and printed reference manual, online assessment and certification passes, and a Toolbox™ user account.

Mechanical, Electrical, and Fluid Power training programs for both industry and mobile systems are available online or via CD-ROM.

FEATURES

- Premier training interface organizes curriculum in a logical sequence
- Interactive learning builds content mastery and troubleshooting expertise
- Pre- and post-test certification ensures mastery of skills
- 3D animations illustrate in real time how equipment works
- Self-paced learning increases retention and job skills
- Video narrations guide training step by step
- Courseware is updated and reviewed regularly to ensure accuracy

MECHANICAL TRAINING

Lab-Volt's Industrial Mechanical Course, Model 47904, gives trainees an overview of the basic physics laws, schematics, and systems design associated with mechanical power transmissions. Trainees learn about the various components found in a typical mechanical system, and how these components function and interact with each other.

TOPIC COVERAGE

- Review energy, torque, and horsepower
- Learn how linear actuators convert rotational motion into linear motion
- Compare clutches and their components, capabilities, and applications
- Understand how bearings are used within mechanical power transmissions

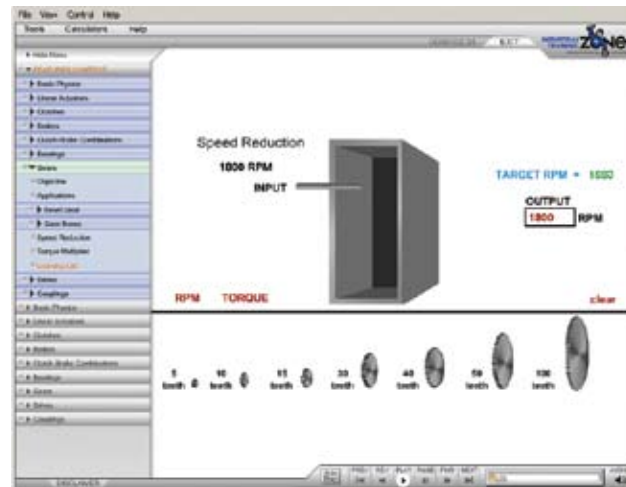

Model 47904

Mechanical Speed Reduction Learning Lab

- Review gears, how they operate, and when they are best used to transmit power
- Review belt and chain drives, how they are designed, and their operation
- Study the features, applications, and functions of different couplings

PLC FUNDAMENTALS

The Programmable Logic Controller (PLC) course, Model 47910, delivers an interactive training experience designed to teach trainees PLC operation, how to connect devices to a PLC, and how to read and write basic PLC ladder-logic software programs.

TOPIC COVERAGE

- Learn how PLC hardware differs from other computers
- Discover the math functions related to PLCs
- Learn how PLC systems store data, memory processes, and data operations
- Master the language of PLCs and learn how to upload to and download from a PLC
- Apply logic to a process by connecting your PLC to another device
- Link your PLC to your production time, and control when operations happen
- Tally the quantity of your automated processes with PLC counters

WEB-BASED INDUSTRIAL TRAINING

For Fluid Power Applications

HYDRAULICS TRAINING

Lab-Volt offers online and CD-ROM-based hydraulics training for both industrial and mobile markets. The Industrial Hydraulics course familiarizes students with the components, functions, and interactions of hydraulic systems. Mobile Hydraulics covers the basics of hydrostatic transmissions, valves, and maintenance systems common to most combustion engines.

TOPIC COVERAGE

Industrial Hydraulics, Model 47901

- Review horsepower, torque, heat, flow, and pressure
- Study gear, vane, and piston pumps, and their fluid displacement capabilities and applications
- Study force manipulation using control valves, the two basic designs and their operation
- Observe how directional control valves operate, start, stop, and change the direction of fluid flow
- Study fluid conditioning and temperature implications
- Understand the function of different valves and where they are used
- Study conductors and how they carry fluid to various components in hydraulic circuits
- Review basic symbols and layout of a hydraulic schematic
- Study components, pictures, and labeling of hydraulic power units

Mobile Hydraulics, Model 47906

- Learn how actuators convert hydraulic horsepower into mechanical horsepower
- Study the basic operation of hydrostatic circuits
- Study force manipulation using control valves
- Experience the application and location of flow control valves
- Learn how modular control valves enhance system design
- Study fluid conditioning and temperature implications
- Study how conductors carry fluid to various components in hydraulic circuits
- Review basic symbols and layout of a hydraulic schematic



3D Simulation of a Piston Pump

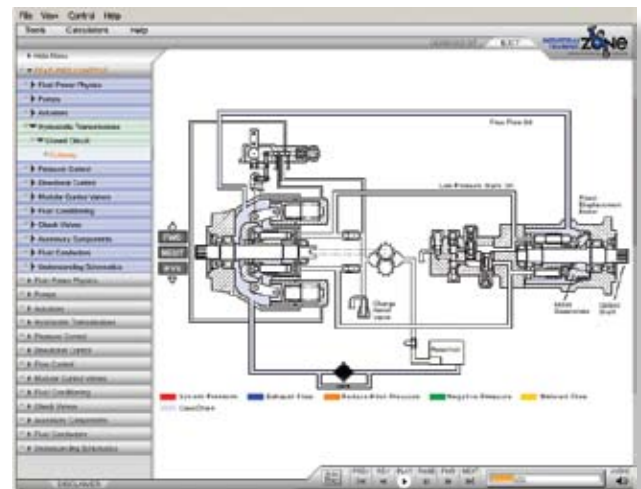

Cutaway View of a Closed Circuit Hydrostatic Transmission

WEB-BASED INDUSTRIAL TRAINING

For Fluid Power Applications

PNEUMATICS TRAINING

Lab-Volt's Industrial Pneumatics course focuses on the basic physics laws, schematics, and system design associated with pneumatic systems and fluid power.

In addition to this course, a Pneumatic Specialist course has been developed in collaboration with the Fluid Power Society and CFC-Solar to help trainees understand the concepts related to the successful design and interaction of pneumatic systems as a Certified Pneumatic Specialist.

TOPIC COVERAGE

Industrial Pneumatics, Model 47902

- Review energy, torque, and horsepower
- Safely and efficiently operate compressors
- Discover the way air is dried to help preserve metal parts exposed to air pressure
- Study the steps to filter, regulate, and lubricate air before use
- Review the designs, techniques, port layouts, and pressure configurations for operation
- Learn interface components that convert pneumatic energy into mechanical energy
- Review airline conductors and how they carry air throughout the pneumatic circuit
- See demonstrations on how vacuum is created to help systems work
- Identify the basic symbols of a pneumatic schematic and learn to read system layouts

Pneumatic Specialist, Model 47909

- Review ratios, torque, speed, and friction
- Compute air cylinder pressure and identify the fault in a pneumatic circuit
- Study air cylinder velocity, circuits, conductor sizes, and input components
- Calculate pressure, cfm, oil flow rate and pressure, torque output, and kinetic energy
- Analyze control components and systems such as electrical, position feedback, series-parallel, pneumatic, and logical control circuits
- Prepare for the certification exam using the study guide and other references

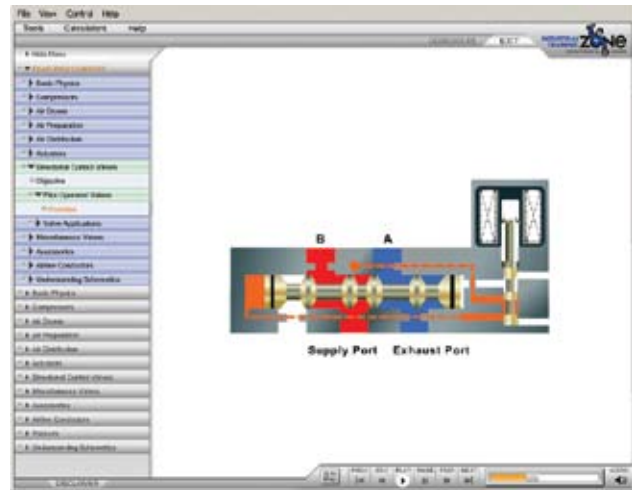

Overview of Pilot-Operated Valves

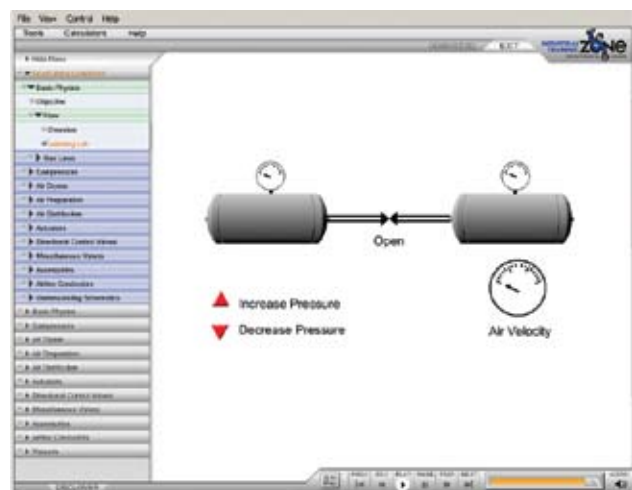

Pressure Differential Learning Lab

WEB-BASED INDUSTRIAL TRAINING

Electricity & Electronics

Electrical Training

Lab-Volt's Industrial Electrical course delivers an interactive training experience designed to help trainees understand the fundamental concepts of electrical systems. This course is popular among those who need to understand the workings of electrical systems on the production floor.

Mobile Electrical covers electrical systems of mobile equipment, including the basic electrical system common to most combustion engine vehicles.

AC/DC Motor and Drives helps trainees understand how electrical motors and drives work with each other and other systems. Trainees also learn about the safety considerations associated with operating electromechanical systems.

TOPIC COVERAGE

Industrial Electrical, Model 47903

- Review basic physics laws that govern electrical systems
- Study circuit components and laws governing circuit voltage and current
- Analyze the effects of circuit components connected in various configurations
- Learn how magnetic fields interact with each other
- Understand how electrical circuit components convert electrical energy into other energy forms
- Review how technology has improved electrical testing, and study safety guidelines

Mobile Electrical, Model 47907

- Review basic physics laws that govern electrical systems
- Study circuit components and laws governing circuit voltage and current
- Analyze the effects of circuit components connected in various configurations
- Learn how magnetic fields interact with each other
- Understand how electrical circuit components convert electrical energy into other energy forms
- Study how lead-acid batteries operate, and how charging and starting systems work in most combustion engine vehicles

AC/DC Motors and Drives Model 47908

- Basic terms and principles of motors and drives
- How torque and magnetism produce power
- Learn what to consider when selecting a replacement drive
- Review fuses and filtering devices
- Learn what causes electrostatic discharge and how to avoid this
- Learn about the functions, components, and firmware of different drives
- Compare different braking methods and their advantages and disadvantages

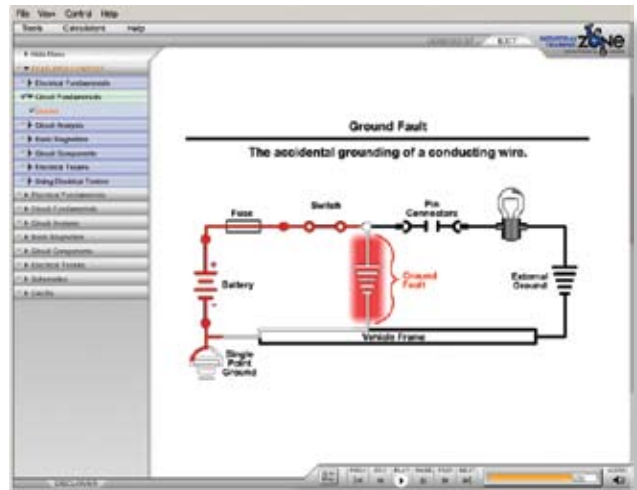

Demonstration of a Ground Fault

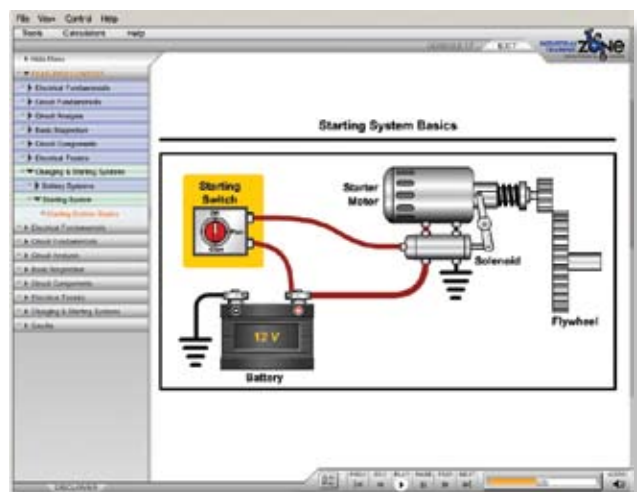

Overview of Charging & Starting Systems

- Study five different electrical measuring tools used to diagnose problems
- Program, maintain, and troubleshoot drives using a human interface module (HIM)

HEATING, VENTILATION, AND AIR CONDITIONING (HVAC) Complete Training Systems for HVAC Technicians



The skills and knowledge required for a technician's job in the field of Heating, Ventilation, and Air Conditioning (HVAC) are the focal point of the many training systems developed by Lab-Volt in this area of technology.

Lab-Volt's modular training approach allows for great flexibility in the choices available to instructors of HVAC. At the basic level of the Lab-Volt program is the Refrigeration System Demonstrator, Model 3400, which introduces students to the physics and devices involved in refrigeration and heat pump systems. From there, the program progresses to more advanced training in domestic and commercial applications, troubleshooting, and repair of refrigeration and heat pump systems. For advanced studies, the trainer for Air Handling and Energy Management incorporates programmable logic controller (PLC) system control of air flow, humidity, and temperature.

Stand-alone and expandable training modules are available to demonstrate several topics related to refrigeration technology, including refrigerant recovery methods. In addition to the system trainers, Lab-Volt offers a number of training units that are in kit form and are assembled and disassembled by the students. These units incorporate all components found in specific HVAC systems and enhance the students' understanding of the underlying principles of the system devices.

At the same time, students improve proficiency in the manual skills that are required by all HVAC technicians. These include: wiring, piping, evacuating, charging, testing, and troubleshooting.

A wide variety of HVAC applications are covered in the Lab-Volt program, including:

- Industrial refrigeration systems
- Commercial/industrial air handling and energy management
- Domestic heat pumps
- Domestic freezers
- Beverage coolers
- Dual-temperature refrigerator
- Walk-in coolers
- Forced-air conditioning
- Universal refrigeration

As with all Lab-Volt training systems, each HVAC training unit is manufactured with industrial-quality components and provides complete, comprehensive, hands-on curriculum and troubleshooting exercises that prepare students for jobs in the field of HVAC.

NOTE: Charging (with optional Refrigeration Charging Equipment, Model 3440) is required upon delivery of all HVAC training systems.

REFRIGERATION TRAINING SYSTEMS

Models 3400 AND 3401



Model 3400: Refrigeration System Demonstrator

The Refrigeration System Demonstrator, Model 3400, is an integrated training system that demonstrates the component designs and operating principles of refrigeration and heat pump systems. The demonstrator is mounted on a wide panel, which displays a multi-colored schematic diagram showing the interconnection among components. Four manual valves reverse refrigerant flow for demonstrations of the heat pump.

TOPIC COVERAGE

- Physics Applied to Refrigeration
- Introduction to Refrigeration
- The Compressor
- The Evaporator and Condenser
- Metering Devices
- System Control Devices
- Introduction to Heat Pump Systems
- Refrigeration Faults

FEATURES

- Shatterproof, clear tubing sections within the evaporator and condenser coils
- Clear evaporator and condenser coil enclosures
- Four manual valves
- Variable-speed fans and adjustable dampers
- A multicolored, silk-screened functional panel
- Six fault-insertion switches
- Elementary refrigeration demonstrator to identify refrigerant change of state
- Instrumentation including temperature meter, compound gauges, pressure gauges, circuit breakers, indicator lamps, and gauge manifold
- Circuit breakers and a safety pressure switch to protect the system
- R-134a Refrigerant

SYSTEM VOLTAGES: 120 V, 60 Hz; 220 V, 50 Hz; 240 V, 50 Hz

ESTIMATED PROGRAM HOURS: 46 hours

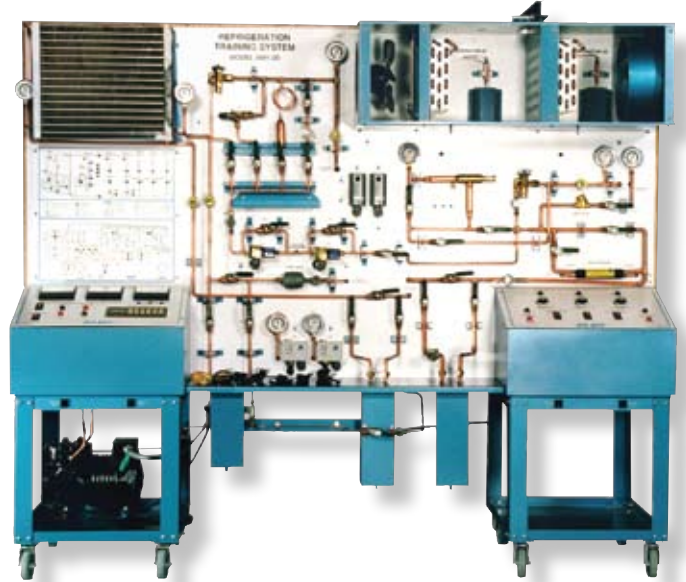

Model 3401: Refrigeration Training System

The Refrigeration Training System, Model 3401, is an integrated training system designed to introduce students to the principles and components of a refrigeration system using industrial and commercial devices. The training system is equipped with a high back-pressure compressor, forced-air condenser and twin forced-air evaporators that can be used individually or linked in series. An interconnected schematic panel enables students to work individually or in pairs to perform simultaneous measurements.

TOPIC COVERAGE

- | | |
|--|-----------------------------------|
| ● Introduction to the Trainer | ● Layout Diagrams of System Panel |
| ● Setup | ● Mechanical Service Analysis |
| ● Receiver, Accumulators, Oil Separators | ● Troubleshooting Flow-chart |
| ● Compressor | ● Pressure Superheat Analysis |
| ● Operation of Metering Devices | ● Vapor Pressures of Refrigerants |
| ● System Control Services | ● Conversion Factors |
| ● Evaporator and Condenser Principles | ● Glossary of New Terms and Words |
| ● Refrigeration Systems | |
| ● Variations of System Loading | |
| ● System Troubleshooting | |

FEATURES

- Chambers, with clear acrylic windows
- Variable-speed fans and adjustable damper
- Schematic panel with multicolored electrical and tubing schematics, as well as indicator lamps and functional duplication of test points
- Lockable fault-insertion switches to introduce 18 distinct electrical faults
- Instrumentation including temperature meter; watt, volt, ampere meters; and pressure gauges
- Circuit breakers and safety pressure switch to protect the system
- R-134a Refrigerant

SYSTEM VOLTAGES: 120 V, 60 Hz; 220 V, 50 Hz; 240 V, 50 Hz

ESTIMATED PROGRAM HOURS: 65 hours

REFRIGERATION TRAINING SYSTEMS

Models 3402 AND 3403

**Model 3402: Heat Pump Training System**

The Heat Pump Training System, Model 3402, provides advanced instruction in the components and operation of a heating system based on heat pump technology. The system includes a heat pump mounted on the front of the training panel, with built-in compressor, condenser, evaporator, four-way valve, and controls. An environmental chamber mounted on the front of the panel simulates a domestic installation, with inlet and outlet ducting, temperature sensors, and controls that enable a wide range of operating conditions.

TOPIC COVERAGE

- Trainer Familiarization
- Manual Thermostat Operation
- Electric Heating
- Defrosting
- Programmable Thermostat Operation
- Troubleshooting

FEATURES

- Blowers and ducting simulate distribution methods of heating and cooling
- AC test meter for troubleshooting activities
- Electric heat for secondary heating
- Four-way reversing valve
- Capillary tube controls with check valves
- Controls including manual and programmable thermostats, fan/limit temperature sensor, high-pressure controller, low-pressure controller, and defrost timer
- Auxiliary control panel with multicolored electrical and tubing schematics, as well as indicator lamps and functional duplication of test points
- Manual/auto fan control, air conditioning electric heat, heat pump, and programmable thermostat

SYSTEM VOLTAGES: 120 V, 60 Hz; 220 V, 50 Hz; 240 V, 50 Hz

ESTIMATED PROGRAM HOURS: 25 hours

**Model 3403: Air Handling/Energy Management Training System**

The Air Handling/Energy Management Training System introduces students to the principles and components of air handling/energy management while developing an appreciation for the methods used to control air and energy. The unit includes fresh air, return air, and exhaust air ducts. A variable-speed blower and mixing dampers (motor driven and mechanically linked) are used to control air flow. A cooling coil, complete with condensing unit, and electric preheat and reheat provide the temperature variations. A humidifier and dehumidifier are provided to condition the circulating air. Thermoplastic windows on the trainer ducting allow students to observe the operation of all air-handling devices.

TOPIC COVERAGE

- Air Flow Control
- Temperature Control
- Humidity Control
- The PLC-5 Programmable Logic Controller
- SCADA Data Acquisition and Monitoring
- PID Control of Temperature and Humidity

FEATURES

- Electric and manually operated mixing dampers
- Operation in manual mode or automatic (PLC-controlled)
- Humidifier and dehumidifier
- Cooling coil (with condensing unit) and electric preheat and reheat
- Thermoplastic windows on ducting
- Sixteen fault-insertion switches
- Fresh air, return air, and exhaust air ducts
- Monitoring of air velocity, humidity, and temperature
- R-134a Refrigerant

SYSTEM VOLTAGES: 120/208 V, 60 Hz 3 ϕ

ESTIMATED PROGRAM HOURS: 20-50 hours

REFRIGERATION TRAINING SYSTEMS

Models 3404 AND 3406



Model 3404: Air Handling Training System

The Lab-Volt Model 3404 Air Handling Training System introduces students to the principles and components of air handling systems. The trainer clearly demonstrates the applications of air handling principles. It helps students develop an appreciation for control methods.

Temperature, humidity, and air flow can be controlled separately or together in two distinct zones using local (thermostats and humidistats) or PLC control. The programmable logic controller (PLC) is an Allen Bradley SLC-500 providing on/off control. Proportional-integral-differential, or PID, control of one zone can be achieved using a microprocessor-based process controller.

TOPIC COVERAGE

- Air Flow Control
- Temperature Control
- Humidity Control
- PID Control of Temperature
- The Programmable Logic Controller
- PLC Control of Temperature and Humidity
- Temperature and Humidity Control of Two Zones
- Air Conditioning Systems and Heat Loads

FEATURES

- Exterior air conditioner (warm or cold fresh air)
- Local or PLC-controlled, motor-driven mechanically-linked mixing dampers
- Humidifier and dehumidifier
- Cooling coil (with condensing unit) and electric pre-heat and reheat apparatus
- Thermoplastic windows on ducting
- Sixteen fault insertion switches
- Fresh air, return air, and exhaust air ducts

SYSTEM VOLTAGES: 120/208 V, 60 Hz, 3 ϕ

ESTIMATED PROGRAM HOURS: 20-50 hours

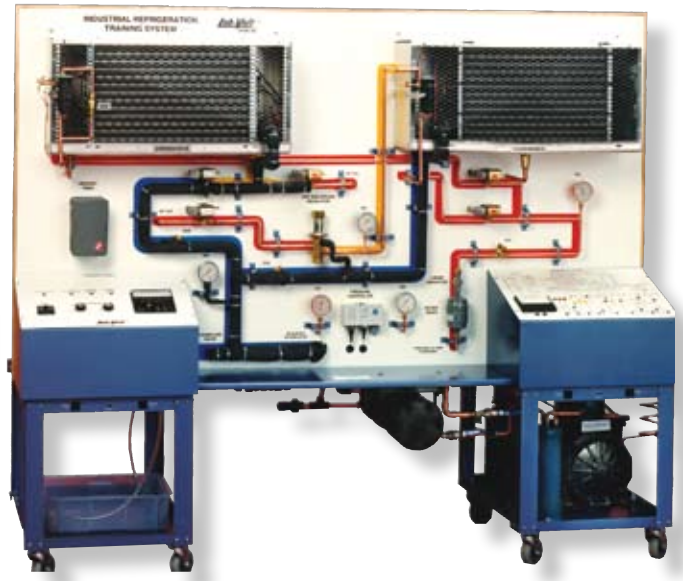

Model 3406: Industrial Refrigeration Training System

The Industrial Refrigeration Training System, Model 3406, introduces students to the principal components of industrial refrigeration systems, providing hands-on experience with industrial equipment that uses water-cooled condensers, electric and hot-gas defrost systems, and hot-gas by-pass for variable load control. Lockable fault-insertion switches help students to develop their skills in maintenance and troubleshooting. The Industrial Refrigeration Training System has been designed to work with city water.

TOPIC COVERAGE

- Introduction to the Lab-Volt Industrial Refrigeration Training System
- Compressors
- System Control and Metering Devices
- Defrost Systems
- Troubleshooting

REFRIGERATION TRAINING SYSTEM with DATA ACQUISITION

Model 3431



The Lab-Volt Refrigeration Training System, Model 3431, is a compact trainer designed to teach the fundamentals of refrigeration. It demonstrates the operation of typical refrigeration systems, using industrial and commercial devices.

The compactness of the trainer allows its placement on a table or a bench, reducing the floor space requirements. Featuring the latest versions of refrigerant and components available on the market, the trainer ensures up-to-date training.

The trainer consists mainly of a hermetic-type compressor with thermal protection, forced-air coil evaporator and condenser, and three types of expansion (metering) devices selectable by using manual valves: a thermostatic expansion valve and two capillary tubes of differing lengths. One of the capillaries is designed to permit observation of the system operation under normal conditions; the other capillary is designed to simulate the effect of a partially obstructed capillary.

The system can be tested under various heat load conditions. Thus, one heat source, located in the cooling chamber, can be turned on and off, while the rotation speed of the evaporator and condenser fans can be varied.

FEATURES

- Compact design allows the placement of the trainer on a table or a bench.
- Cooling chamber with acrylic window
- Commercial condensing unit using the R-134a refrigerant.
- Forced-air coil condenser with variable-speed fan.
- One thermostatic expansion valve and two capillary tubes of differing lengths.
- Electronic pressure controller with LCD display and adjustable cut-in and cut-out pressures.
- Remote-bulb thermostat with adjustable differential.
- Heat load simulation using two light bulbs.
- Seven thermocouple transducers and three pressure transducers used to acquire 22-bit data at the critical points of the system.
- Conditioning of the compressor voltage and current.
- Fault-insertion switches, accessible to the instructor behind a lockable hinged panel.
- High-pressure safety switch with manual reset breaker.

SYSTEM VOLTAGES: 120 V, 60 Hz; 220 V, 50 Hz; 240 V, 50 Hz

REFRIGERATION SKILLS TRAINERS

Models 3410 – 3415 and 3420



**Model 3410
Domestic Freezer
Skills Trainer**



**Model 3411
Heat Pump Skills
Trainer**



**Model 3412
Beverage Cooler
Skills Trainer**



**Model 3413
Dual Temperature
Refrigerator Skills
Trainer**



**Model 3414
Walk-In Cooler
Skills Trainer**



**Model 3415
Air Conditioner
Skills Trainer**



**Model 3420
Universal Refrig-
eration Skills
Trainer**

The Lab-Volt Skills Trainers are designed to teach the basic skills of wiring, piping, evacuating, charging, testing and troubleshooting. They are designed to be assembled, tested, and disassembled by one or two students performing a series of tasks.

Available Trainers include:

- Domestic Freezer Skills Trainer, Model 3410: Provides a basic understanding of the applications of a standard condensing unit and a natural convection evaporator.
- Heat Pump Skills Trainer, Model 3411: Includes the basic components of a typical heat pump unit and can be operated in two modes: the cooling mode or the heating mode.
- Beverage Cooler Skills Trainer, Model 3412: Includes the basic components of a commercial refrigerating system.
- Dual Temperature Refrigerator Skills Trainer, Model 3413: Provides a basic understanding of a two-stage cooling system such as that found in a typical two-compartment refrigerator.
- Walk-In Cooler Skills Trainer, Model 3414: Provides a basic understanding of the applications of forced-air evaporators and water cooled condensers.
- Air Conditioner Skills Trainer, Model 3415: Includes the basic components of a typical air conditioning unit.
- Universal Refrigeration Skills Trainer, Model 3420:

Provides hands-on training in the principles and components of universal refrigeration units.

TOPIC COVERAGE:

- Conduit Assembly
- Wiring the Skills Trainer
- Installing Tubing
- Testing for Leaks, Evacuation, Charging, and Troubleshooting
- Mechanical/Electrical Service Analysis and Assembly Drawings

REQUIRED EQUIPMENT

- Refrigeration Charging Equipment, Model 3440**
- Refrigeration Tool Cabinet, Model 3441
- Refrigerant Recovery Unit, Model 3445

RELATED SYSTEMS

Lab-Volt Model 3400 Refrigeration System Demonstrator, Model 3401 Refrigeration Training System, and Skills Trainers

SYSTEM VOLTAGES: 120 V, 60 Hz; 220 V, 50 Hz; 240 V, 50 Hz

****Charging is required upon delivery.**

EXPLORING MANUFACTURING TECHNOLOGY

Compact Training Modules for a Hands-On Introduction to Manufacturing Technology

Lab-Volt Systems developed the Exploring Technology series of training modules to serve as a hands-on introduction to the principles and basic applications of sensors, mechanisms, and electricity.

Each module in the Exploring Manufacturing Technology series can accommodate two students. Modules can be studied individually and then inter-connected with the use of electrical leads, allowing for further study and problem solving by students who complete the study of a module.

Included with each module is a fully illustrated manual containing ten exercises, written in an easy-to-read, step-by-step format, divided into the following five units:

- » **Objective:** A statement outlining the purpose of the exercise
- » **Discussion:** A topic description with background information
- » **Procedure:** A step-by-step guide for performing experiments
- » **Conclusion:** A brief review of the topic and related practical examples
- » **Question:** A multiple-choice test to determine student comprehension

CHASSIS DIMENSION

Depth	Width	Height
24 cm	49 cm	33.5 cm
9-1/2 in	19-1/4 inc	13-1/4 in

POWER REQUIREMENTS

120, 220, 240 V - 50/60 Hz

ESTIMATED PROGRAM HOURS

Open

EXPLORING SENSORS

Model 3341

The Exploring Sensors module, Model 3341, allows students to explore the different uses of mechanical and electronic sensors from a security applications viewpoint.

Students are introduced to the variety and characteristics of sensors. They build a variety of circuits using magnetic sensors, vibration/shock sensor, pulsed infrared sensors, and motion sensors. Students also build alarm circuits using sensors, an electromechanical relay, and a buzzer.

Sensors in this module include an infrared photoelectric beam sensor, an infrared motion detector, a mechanical switch, a vibration detector, and magnetic proximity sensors.

TOPIC COVERAGE

- Getting to Know the Trainer: How to Connect Sensor Circuits
- Control Panels
- Introduction to Mechanical Sensors - The Plunger Switch
- Magnetic Proximity Sensors
- Shock/Vibration Sensors
- Electronic Active Sensors
- Electronic Passive Sensors
- Wiring Installation Techniques
- Automobile Alarm System
- Designing an Alarm System

FEATURES

- Regulated 12 VDC source
- Proximity sensor, infrared-sensor, shock/vibration sensor, and motion sensor
- Plunger switch
- Electromechanical relay
- Buzzer alarm and indicator lamps

LANGUAGE VARIATIONS

English, Spanish



EXPLORING MECHANISMS

Model 3342



The Exploring Mechanisms module, Model 3342, introduces students to the world of mechanical power transmission. Using a fully operational elevator, the module covers the topics of work, power, force, energy, and torque.

The module comes fully equipped with a collection of gears, belt drives, and a chain drive. Other topics include direction of rotation and tension. Practical examples and association with real world examples set this module apart from others.

TOPIC COVERAGE

- Introduction to the Trainer
- Work and Power
- Friction
- Mechanical Advantage
- Inclined Plane
- Gears and Gear Trains
- Friction-Belt Drives
- Synchronous-Belt Drives
- Chain Drive
- Pulley System

FEATURES

- DC driving motor with control switch
- Assortment of gears, O-rings, chains, and belts
- Lift (elevator) with control switch, and upper/lower sensors
- Hex keys and spring scale

LANGUAGE VARIATIONS

English

EXPLORING ELECTRICITY

Model 3343



The Exploring Electricity module, Model 3343, plays a vital role in every area of technology. This module teaches students the basic characteristics of simple electrical circuits.

The module is provided with a built-in regulated 12-Volt DC source. Other components include a digital multimeter, an electromechanical relay, and an assortment of lamps, switches, and resistors.

Students build a variety of circuits using electrical leads. These circuits are series circuits, parallel circuits, and logic circuits. Students also learn how to calculate electric values and measure them with the digital multimeter.

TOPIC COVERAGE

- Electric Circuits
- Measuring Voltage, Current, and Resistance
- Series Circuits
- Parallel Circuits
- Logic Circuits
- Three-Way Switching Circuits
- Ohm's Law
- Ohm's Law for Series Circuits
- Ohm's Law for Parallel Circuits
- Electromechanical Relays

FEATURES

- Regulated 12 VDC source
- Digital Multimeter
- Assortment of resistors, switches, relays, and indicator
- Fan used as a circuit load

LANGUAGE VARIATIONS

English, Spanish

PRACTICAL ELECTRICITY AND ELECTRONICS TRAINER (PEET)

Model 556



The modular Preparatory Electricity and Electronics Trainer (PEET) is ideally suited for skill development in the Fundamentals of AC/DC, Basic Electronics, and Motors and Generators. These three modules comprise the PEET system and can be purchased as stand-alone units or as a system. The PEET system includes all components along with a storage enclosure.

Three manual skills packages that provide practical experience in building and testing printed circuit boards (PCB) also may be ordered as stand-alone or system units. Each skills package contains components for assembling a PCB, along with a student manual and all the hardware required to assemble the projects.

PEET hardware includes Lab-Volt's unique Konnect-All breadboard that allows students to build circuits easily. Required equipment includes an AC/DC power supply, electronic VOM, sine/square-wave generator and DC meter. This equipment is available in the Lab-Volt Laboratory Instrument System, Model 438.

TOPIC COVERAGE

- Fundamentals of AC/DC
- Basic Electronics
- Motors and Generators

LANGUAGE VARIATIONS

English, French, Spanish

LABORATORY INSTRUMENTATION SYSTEM

Model 438



The Lab-Volt Model 438 Instrumentation System is a general-purpose instrument module consisting of a DC meter, sine/square wave generator, electronic volt-ohm-millimeter (VOM) and AC/DC power supply.

These instruments are housed in an attractive enclosure that complements the Model 556 Series Practical Electricity and Electronics Trainer (PEET). The module may be permanently attached to a bench; an optional locking cover (Model 1204) is available for added security.

Both the electronic VOM and DC meters have easy-to-read scales and provide simultaneous measurement of voltage and current. Each instrument is fully protected against improper voltage and current connections. All minus and common jacks are isolated from the chassis.

The sine/square wave generator has separate outputs to supply both wave shapes simultaneously. The frequency is selectable in four ranges from 50 Hz to 500 kHz. The sine wave output is continually adjustable from 0 to 6.0 Vp-p. A fixed, 1 kHz signal is switch-selectable for 50% internal modulation of the sine wave.

The AC/DC power supply is a fully protected source for four switchable AC voltages and two continuously adjustable DC ranges. An illuminated switch controls power to the entire instrument system.

The lead set and an instruction manual are provided with the system.

LANGUAGE VARIATIONS

English, French, Spanish

Available from Lab-Volt:

Lab-Volt Product Catalog on CD-ROM

Descriptions and demonstrations of Lab-Volt training systems and software. Includes FACET®, EMS, and other award-winning training systems.



Computer-Based Electronics Training System (FACET®) Product Guide

Fifty-two-page catalog of Lab-Volt training systems in Fundamental Electronics; Analog, Digital and Fiber Optic Communications; Semiconductors; Transistors, Thyristors, FET, and Amplifiers.



Military Training Systems Brochure

State-of-the-art training systems for military applications in telecommunications, radar, electronic warfare, electronics, fluid power, and electric power technologies. 12-page color brochure.



Industrial Maintenance Brochure

Twelve-page color brochure showcasing Lab-Volt's comprehensive industrial training systems, including industrial pumps, mechanical systems, industrial wiring, rigging, and more.



Electric Power/Controls Product Guide

Fifty-two page catalog of Lab-Volt's vast offering of training modules in Electro-Mechanical Systems, PLCs, Power Electronics, and corresponding CBT and simulation software programs.



E-Blocks™: Modern Electronics Teaching Resources

30-page catalog detailing E-Blocks™ small circuit boards, each of which contains a block of electronics typically found in an electronic system. E-Blocks provide a very flexible set of parts for learning a range of technical disciplines.



Graymark Information Technology Brochure

Eight-page brochure of Graymark's quality IT training products, including PC familiarization, troubleshooting and repair; cable installation; monitor and printer repair; GPS technology; and network technology programs.



Fluid Power Brochure

Twelve page 4-color brochure featuring Lab-Volt's premier line of Fluid Power training systems, including the Hydraulics and Pneumatics Modular Training Systems.



Tech-Design® Foundations in Information Technology (FIT)

Sixteen-page color brochure features this modular, competency-based curriculum for information technology (IT), which provides skills development and career exploration in the four IT career Cluster Concentrations.



Tech-World®: Manufacturing Brochure

Twelve-page color brochure describes this multimedia and hands-on curriculum for engineering and manufacturing; presents competencies students achieve and related career opportunities.



Tech-Design® Technology Education Catalog

Seventy-four-page catalog with detailed descriptions of 43 Tech-Design modules and course objectives, including skills-at-a-glance charts showing competencies associated with each module.



Industrial Training Zone by Lab-Volt

11-page Industrial Training Zone by Lab-Volt brochure details the broad range of online industrial training courses designed to help you build a more competent, qualified, and efficient workforce.



4 Easy Ways to Order Additional Product Literature:

- ✓ Send e-mail to: us@labvolt.com (USA)
ca@labvolt.com (Canada)
- ✓ Call us at 1-800-LAB-VOLT (USA AND CANADA)
or 1-732-938-2000 (outside of the USA and Canada)
- ✓ Visit our website at www.labvolt.com
- ✓ Circle the requested items above and fax to: 1-732-774-8573

Please complete the following:

Name _____
Institution _____
Address _____
Address 2 _____
City _____ State _____
Country _____ Postal Code _____



Building Training Systems for the Global Workplace

For 50 years, Lab-Volt has been a global leader in the design and manufacture of hands-on training laboratories for public education, industry, and the military. Our products prepare students for technical careers in the fields of Electricity and Electronics, Electric Power, Telecommunications, Fluid Power, Instrumentation and Process Control, Automation and Robotics, Manufacturing, Mechatronics, and Air Conditioning and Refrigeration. In our quest to provide our customers with the most cost-effective training solutions available, Lab-Volt has been a pioneer in the development of computer-based training, simulation software, multimedia programs, and classroom management systems.

Some of our better-known products include the FACET® series of computer-based courses in electronics, LVSIM® simulations for training in fields ranging from fluid power to telecommunications, Tech-Design® and Tech-World® for multimedia-based programs in technology education and manufacturing, and Industrial Training Zone® for on-line training in industrial maintenance.

Today, Lab-Volt's highly effective approach to training and education has earned us the distinction as the leading North American producer of hands-on technical training systems. Key to our success has been our ability to anticipate the applications of new technologies and develop modular training systems that allow us to address the basic, as well as specialized, needs of industry and education. In our approach to training and education, we begin by carefully defining each new training need. Next, we methodically design and create the best curriculum, instrumentation, delivery method, management platform, and laboratory furniture to suit real-world training goals and the real needs of students and instructors.

Lab-Volt training systems are carefully balanced to provide a solid theoretical grounding in the subject matter, along with numerous and diverse hands-on applications. By design, our first-quality, industry-standard training systems are modular and open-ended so that students may enter or exit a program at many points. Lab-Volt training systems bring technical theory to life teaching the latest technologies along with valuable troubleshooting, critical thinking, and reasoning skills.

Lab-Volt maintains a staff of educators, instructional system designers, and engineers who are always available to assist teachers, training directors, and administrators in designing program content, selecting or modifying equipment and software, and providing professional teacher training.

In designing our laboratory equipment, we ensure

compatibility with international power requirements that prevail throughout North America, Africa, Asia, Europe, the Middle East, South America, and Southeastern Asia. Whether at a high school or community college in the United States, an air traffic control center in Saudi Arabia, or a technical institute in the Philippines, Lab-Volt training systems provide state-of-the-art teaching and classroom management tools built on computer-mediated platforms that deliver, manage, and control the educational process.

Lab-Volt's systems have been used to train technicians who are successfully employed in leading multinational companies such as General Telephone & Electronics, Lockheed Aviation, United States Steel, Western Electric and Westinghouse, Intel and Micron Semiconductor, Ford Motor Company, General Motors,



IBEW, Verizon New Jersey, and many others. In addition, Lab-Volt-trained technicians hold positions throughout the world at leading colleges, universities, educational ministries, and military installations.

FACET®, Lab-Volt Simulation Systems® (LV-SIM); Lab-Volt Automation™; and Tech-World® by Lab-Volt are among the most widely used integrated technology education systems today. Trainers in over 30,000 schools, industrial sites, and military installations in over 50 countries worldwide use Lab-Volt systems to learn the skills that are necessary to keep up with the world's rapid technological growth well into 21st century.



AUTOMATION & ROBOTICS



FLUID POWER



REFRIGERATION, AIR CONDITIONING & HEATING



ELECTRIC POWER/CONTROLS



INSTRUMENTATION & PROCESS CONTROL



COMPUTER-BASED ELECTRONICS TRAINING SYSTEM



ALTERNATIVE & RENEWABLE ENERGY



DIGITAL MICROPROCESSOR & COMPUTER



ELECTRICITY & ELECTRONICS



TELECOMMUNICATIONS

Lab-Volt[®]

WORLD LEADER IN TECHNICAL TRAINING SYSTEMS